



DOC023.54.03045

FILTRAX

User Manual

06/2024 Edition 9

Contents

Section 1 Technical data	3
Section 2 General information	5
2.1 Safety information.....	5
2.1.1 Use of hazard information	5
2.1.2 Precautionary labels	5
2.2 Applications	6
2.3 Functional description.....	6
2.4 Items supplied	8
2.5 Instrument layout.....	9
2.5.1 Control unit.....	9
2.5.2 Module carrier	9
2.5.3 Sample tubes	10
2.5.4 Filter modules	10
Section 3 Installation	12
3.1 Mechanical installation	14
3.1.1 Dimensions	14
3.2 Installing control unit with control unit bracket LZX676	17
3.3 Connecting tubes.....	21
3.4 Electrical connections.....	26
3.5 Connection to process instruments	28
Section 4 Commissioning	31
4.1 Placing instrument in operation	31
4.2 Taking instrument out of operation	33
4.2.1 Filter modules	33
4.2.2 Control unit.....	33
Section 5 Operation	35
5.1 Using the keypad.....	35
5.2 Menu overview	36
5.3 [+DEVICEDATA] menu	37
5.4 [+SIGNALS] menu.....	38
5.5 [+OP.COUNTERS] menu	40
5.6 [+SERVICE] menu.....	41
Section 6 Maintenance	43
6.1 Maintenance work	43
6.1.1 Weekly	44
6.1.2 Every 3 months	44
6.1.3 Every 12 or 24 months	45
6.1.4 Menu-based cleaning.....	46
6.1.5 Cleaning with cleaning container (option)	47
6.1.6 Cleaning with cleaning set (option)	49
Section 7 Faults, causes, rectification	50
7.1 Messages	50
7.2 Warnings	50
7.3 Faults.....	51
7.4 Voltage drop (power failure)	51

Contents

Section 8 Spare parts	53
-----------------------------	----

Subject to change without notice.

The product has only the approvals listed and the registrations, certificates and declarations officially provided with the product. The usage of this product in an application for which it is not permitted is not approved by the manufacturer.

Table 1-1 FILTRAX

Supply:	230 V (option 115 V) \pm 10% AC, 50-60 Hz			
Power consumption:	Device with system components:			
	Cable	Heater off	Max. (-20° C) start-up	Cont. (-20° C)
	2 m (6.6 ft)	150 VA	450 VA	< 200 VA
	10 m (32.8 ft)	150 VA	950 VA	< 300 VA
20 m (65.5 ft)	150 VA	1500 VA	< 400 VA	
30 m (98.4 ft) ¹	150 VA	2100 VA	< 500 VA	
Sample volume:	approx. 900 mL/h for up to 3 process photometers			
Head:	Module carrier – control unit: 3 m (9.8 ft); control unit – process instrument: 7 m (23.0 ft)			
Outputs: (use screened cable!)	Fault signalling contact: floating contact (230 V, max. 3 A) Warning contact: floating contact (230 V, max. 3 A) Service interface: RS 232			
Cable length:	Suction tube:	5 m (16.4 ft) (heated)		
	Sample tube:	2 m (6.6 ft) (unheated)		
	Sample tube:	10 m (32.8 ft) (heated), 20 m (65.5 ft) (heated), 30 m (98.4 ft) (heated) ¹		
User maintenance:	approx. 1h / month			
Medium temperature:	+5° C to +40° C, 95% relative humidity, non-condensing			
Ambient temperature	-20° C to +40° C, 95% relative humidity, non-condensing			
Enclosure rating:	IP 55			
Fuses:	T 4A E; 250V (2 ×) T 7A E; 250V (2 ×)			
Mass:	Control unit:	approx. 22 kg (48.5 lb)		
	Module carrier with 5 m suction tube:	approx. 9 kg (19.8 lb)		
	Sample tube 10 m (32.8 ft):	approx. 5 kg (11 lb)		
	Sample tube 20 m (65.5 ft):	approx. 10 kg (22 lb)		
	Sample tube 30 m (98.4 ft) ¹ :	approx. 15 kg (33 lb)		
	Mounting pipe 2 m (6.6 ft):	approx. 5 kg (11 lb)		
Dimensions:	Control unit (W x H x D): 430 x 530 x 220 mm (16.9 x 20.9 x 8.7 in.) Module carrier (W x H x D): 92 x 500 x 340 mm (3.6 x 19.7 x 13.4 in.)			

Technical data

Material that touches with sample:	Module carrier metal parts: 1.4571 Welded nuts: 1.4305, 1.3401 Fittings/connectors: 1.4571 Fittings: PP O-rings: NBR Heated tube: PVC Sample tube: PTFE Filter module: ABS, PP/PE, 1.4401
Certification:	CE. The manufacturer clarifies conformity with the applicable EU safety guidelines and EMC guidelines.
Warranty	1 year, (EU: 2 years)
Altitude	2000 m (6561.7 ft)
Pollution degree	2
Overvoltage category	II
Environmental conditions	Outdoor use

1. 30 m (98.4 ft) version is not available at 115V AC.

2.1 Safety information

Please read this entire manual before unpacking, setting up or operating this equipment. Pay attention to all danger, warning and caution statements. Failure to do so could result in serious injury to the operator or damage to the equipment.

Make sure that the protection provided by this equipment is not impaired, do not use or install this equipment in any manner other than that specified in this manual.

2.1.1 Use of hazard information

⚠ DANGER
Indicates a potentially or imminently hazardous situation which, if not avoided, will result in death or serious injury.

⚠ WARNING
Indicates a potentially or imminently hazardous situation which, if not avoided, could result in death or serious injury.



⚠ CAUTION
Indicates a potentially hazardous situation that may result in minor or moderate injury.

NOTICE
Indicates a situation which, if not avoided, may cause damage to the instrument. Information that requires special emphasis.

Note: Information that supplements points in the main text.

2.1.2 Precautionary labels

Read all labels and tags attached to the instrument. Personal injury or damage to the instrument could occur if not observed. A symbol on the instrument is referenced in the manual with a precautionary statement.

	This is the safety alert symbol. Obey all safety messages that follow this symbol to avoid potential injury. If on the instrument, refer to the instruction manual for operation or safety information.
	This symbol indicates that a risk of electrical shock and/or electrocution exists.
	<p>Electrical equipment marked with this symbol may not be disposed of in European domestic or public disposal systems after 12 August 2005. In conformity with European local and national regulations (EU Directive 2002/96/EC), European electrical equipment users must now return old or end-of life equipment to the manufacturer for disposal at no charge to the user..</p> <p>Note: For return for recycling, please contact the equipment producer or supplier for instructions on how to return end-of-life equipment, producer-supplied electrical accessories, and all auxiliary items for proper disposal.</p>

2.2 Applications

The FILTRAX sampling system is a device for the filtration and pumping of waste water samples from the activated sludge tank or final clarification tank for supplying process instruments with samples free of solids.

NOTICE

Any use other than use in accordance with requirements defined in the user manual leads to the loss of the warranty claims and can lead to personal injury and property damage, for which the manufacturer assumes no liability.

2.3 Functional description

The FILTRAX sampling and sample conditioning system comprises two components: a control unit and module carrier.

The module carrier **(1)** is immersed at the place the samples are to be taken using a special tank edge fastening. Inside the module carrier there are two filter modules **(2)**; a filter membrane **(3)** is stretched over both sides of each of the modules. The waste water sample is fed to a special duct system **(4)** via this membrane.

Two tube metering pumps inside the control unit draw the sample alternately from the two filter modules using a common 5 m long heated suction tube to the control unit that is installed in close proximity to the sampling point. From there the sample is pumped 2 m (6.6 ft), 10 m (32.8 ft), 20 m (65.6 ft) or 30 m (98.4 ft)*, depending on the sample tube connected, to the process instruments.

A venting device **(5)** underneath the filter modules largely prevents the adhesion of solids to the filter membranes and significantly reduces the maintenance effort. Two signal lamps (green and red) provide continuous visual indication of normal operation, warnings and faults - this information is also provided electrically by two floating relay contacts.

*. 30 m (98.4 ft) version is not available at 115V AC.

Fig. 2-1 Layout of the filter modules

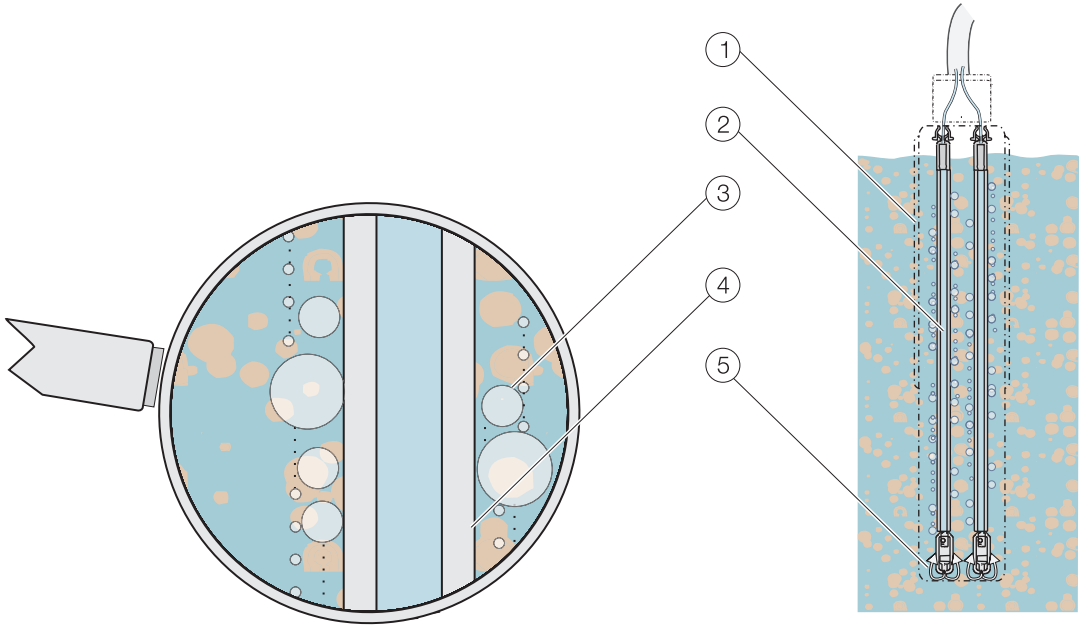

2.4 Items supplied

Fig. 2-2 Items supplied

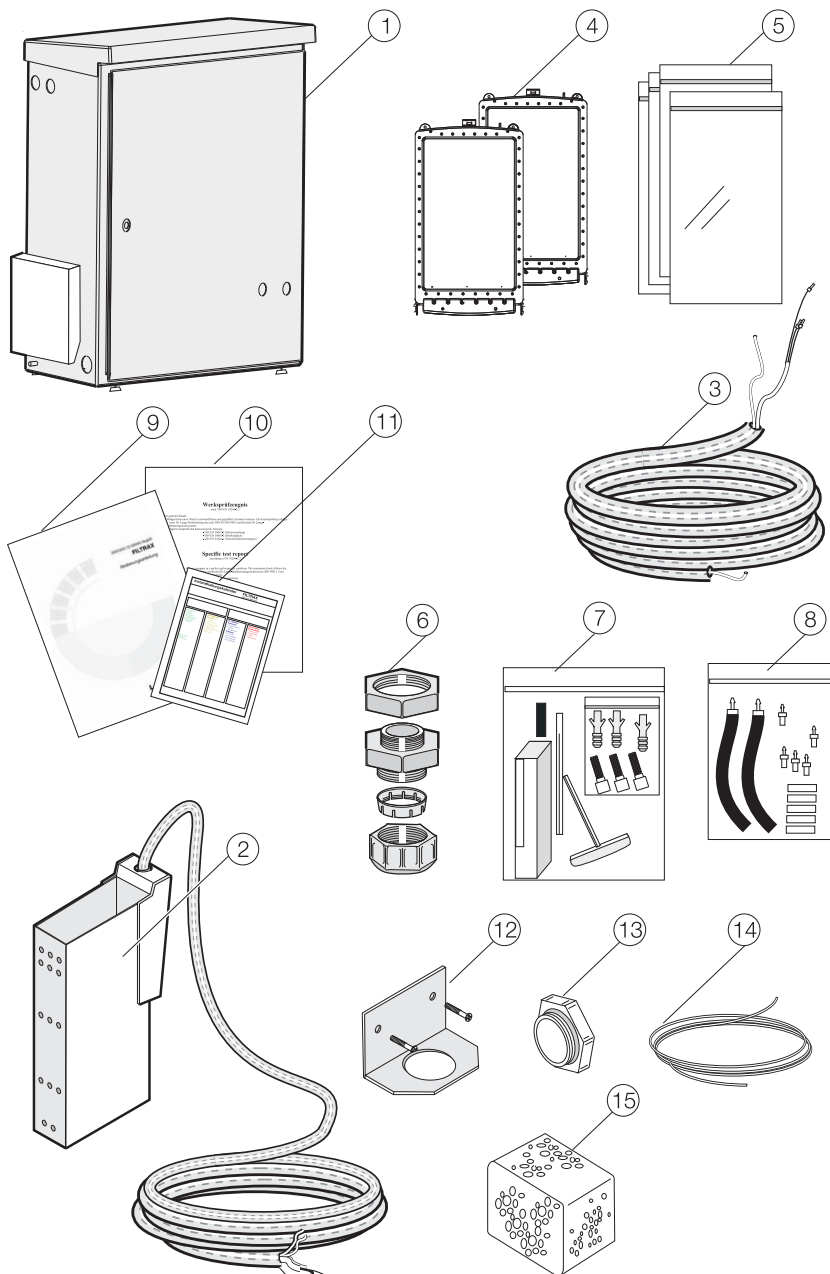

1. Control unit	9. Operating instructions
2. LZX670 (230 V) module carrier with 5 m suction tube	10. Factory test certificate
3. Sample tube 2 m (6.6. ft), 10 m (32.8 ft), 20 m (65.5 ft), 30 m (98.4 ft) ¹	11. DOC273.xx.04006 Maintenance calendar
4. LZX677 Filter module (2)	Included in accessory set LZX702
5. EYV017 Plastic bag for filter module (4)	
6. Cable gland M20 x 1.5 (2)	
7. LZX702 Accessory set	
8. LZX701 Tube adapter set	
	12. Mounting bracket for sample tube
	13. Blanking plugs (2) + sealing rings (2)
	14. HLS191 2/4 tube 6 m
	15. Cleaning sponge
	16. Clip

1. 30 m (98.4 ft) version is not available at 115V AC.

2.5 Instrument layout

2.5.1 Control unit

Fig. 2-3 Control unit

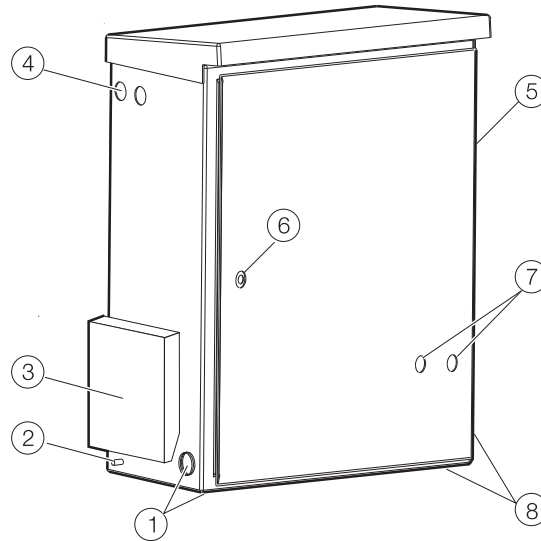

1. Suction tube connection (left or underneath on the left) (Blanking plugs and sealing ring for the unused opening)	5. Air filter cover (air outlet)
2. Connection for equipotential bonding	6. Door lock
3. Air filter cover (air inlet)	7. Green and red signal lamps
4. Cable gland for electrical connecting cable (2)	8. Sample tube connection (right or underneath on the right) (Blanking plugs and sealing ring for the unused opening)

2.5.2 Module carrier

Fig. 2-4 Module carrier

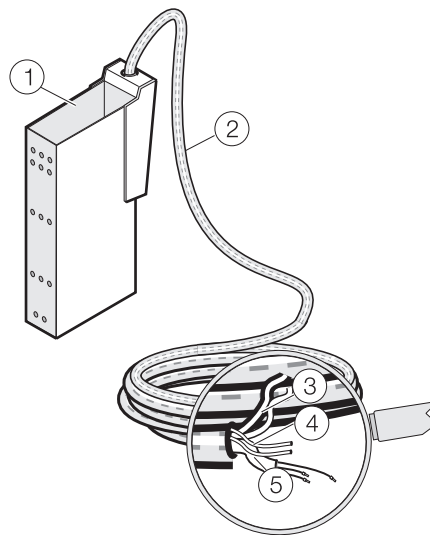

1. Module carrier	4. Sample suction tube 3.2 mm (0.16 in.) OD (2)
2. Suction tube 5 m (16.4 ft)	5. Connecting cable for the tube heater
3. Air tube 6 mm (0.23 in.) OD (2)	

2.5.3 Sample tubes

Fig. 2-5 Sample tubes

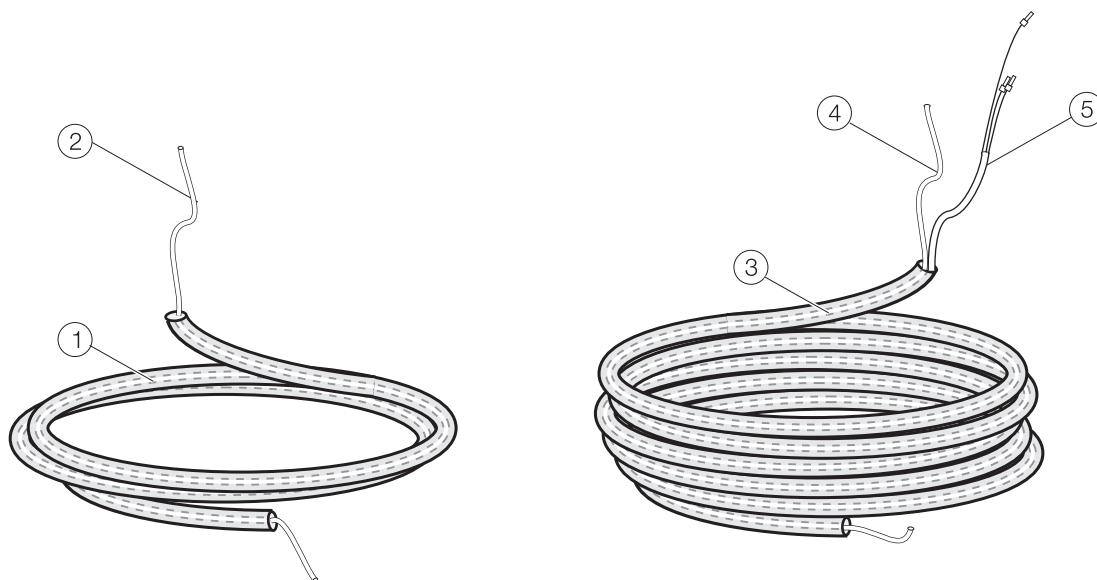

1. Sample tube 2 m (6.6 ft), Ø 23 mm (0.91 in.), not heated	4. Sample pressure tube 3.2 mm (0.13 in.) OD
2. Sample pressure tube 3.2 mm (0.13 in.) OD	5. Connecting cable for the tube heater
3. Sample tube 10 m (32.8 ft), 20 m (65.6 ft), 30 m (98.4 ft) ¹ , Ø 23 mm (0.91 in.), heated	

1. 30 m (98.4 ft) version is not available at 115V AC.

2.5.4 Filter modules

The two filter modules should only be installed during commissioning. Once moistened, the filter membranes must not be allowed to dry out again and are sealed in a plastic bag for protection.

NOTICE

The surface of the membrane is very delicate!

Fig. 2-6 Filter module

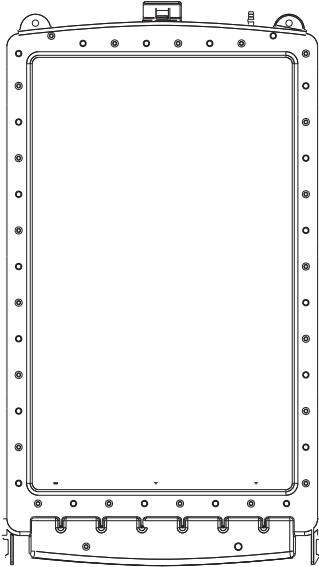

⚠ DANGER

Only qualified experts should conduct the tasks described in this section.

⚠ DANGER

Make sure to select a safe installation location for operation and service. Installation must be carried out by a qualified expert in accordance with all local safety regulations. Plan out the mechanical mount before positioning poles or drilling holes. Make sure the mount has a sufficient bearing capacity. The dowels must be selected and authorized according to the condition of the wall.

The manufacturer shall accept no liability if the instrument is installed incorrectly.

Take care to follow the installation instructions when mounting the product. Make sure that a HACH service technician can remove the product without health risk. Make sure that support from the operator is possible.

Be sure to use only one extension tube (LZY714.99.00040) to increase the length of the holding tube to a maximum of 3.8 m [12.5 ft].

Plan how to lay cables and tubes and their path in advance. Lay the tubes, data cables and power cables without any bends and so they do not pose a tripping risk.

Risk of falling. Make sure to take additional safety measures against falling.

Pinch hazard. When inserting the mounting tabs into the holder can pinch and cause injury to the fingers.

Do not connect the electrical supply to the mains until the instrument is completely wired and protected against short circuits.

Sufficiently protect the electrical power supply against short circuits.

For the external power supply, always connect a residual-current circuit breaker (trip current max.: 30 mA) between the mains and the system.

If the instrument is to be installed outdoors, connect a surge arrester between the mains and the system.

Products intended by the manufacturer for outdoor use offer a higher level of protection against the penetration of liquids and dust. If these products are connected to a mains outlet with a cable and plug rather than a permanently connected cable, the plug and outlet are much more susceptible to liquid and dust penetration. The operator must sufficiently protect the plug and outlet against liquid and dust penetration in accordance with local safety regulations. If the instrument is to be used outdoors, it must be connected to a suitable outlet with a protection type of at least IP44 (splash protection).

⚠ WARNING

Electrical dangers and fire hazard. Use only the supplied power cable.

Only qualified experts may perform the tasks described in this section of the manual, in compliance with all locally applicable safety regulations.

NOTICE

Protect the device against extreme temperatures from heaters, direct sunlight and other heat sources.

⚠ CAUTION

Note the weight (control unit approx. 22 kg, module carrier with 5 m suction tube approx. 9 kg) of the instrument. Do not try to carry the instrument without help. Use only suitable lifting devices for the transport.

Fig. 3-7 Installation overview

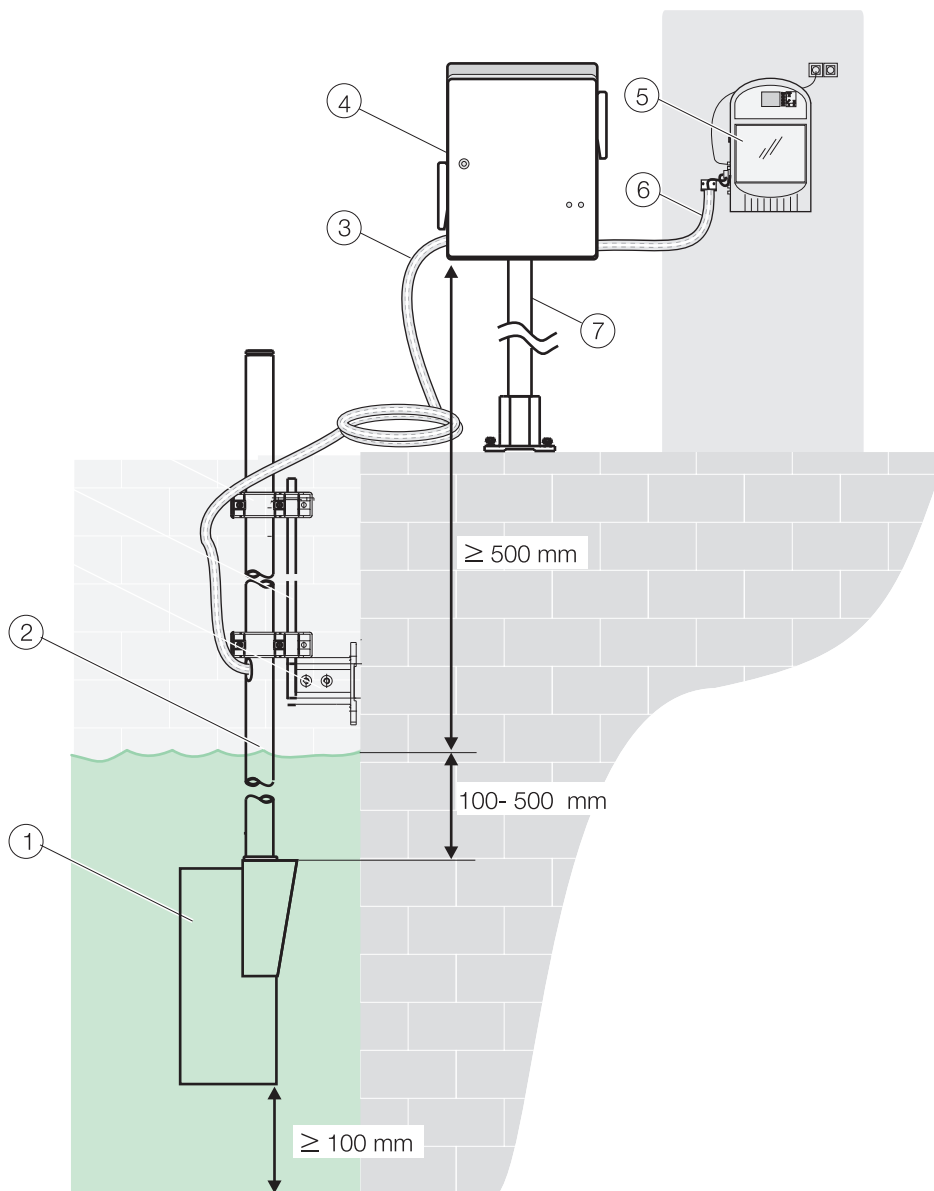

1. Module carrier	5. Process instrument
2. Bracket FILTRAX module carrier (option)	6. Sample tube
3. Suction tube 5 m	7. Bracket FILTRAX control unit (option)
4. Control unit	

3.1 Mechanical installation

⚠ DANGER

Select an appropriate installation location for the instrument.
Plan out the mechanical mount before positioning poles or drilling holes. Make sure the mount has a sufficient bearing capacity. The dowels must be selected and authorized according to the condition of the wall.
The manufacturer shall accept no liability if the instrument is installed incorrectly.
Plan how to lay cables and tubes and their path in advance.
Lay the tubes, data cables and power cables without any bends and so they do not pose a tripping risk.

NOTICE

For information on installation with optional accessories, refer to the relevant installation instructions.

NOTICE

The filter module should only be unpacked directly before commissioning and quickly attached to the module carrier.
The filter membranes are shrink-wrapped in protective plastic; once they have been moistened they must not be allowed to dry out.

3.1.1 Dimensions

Fig. 3-8 Control unit

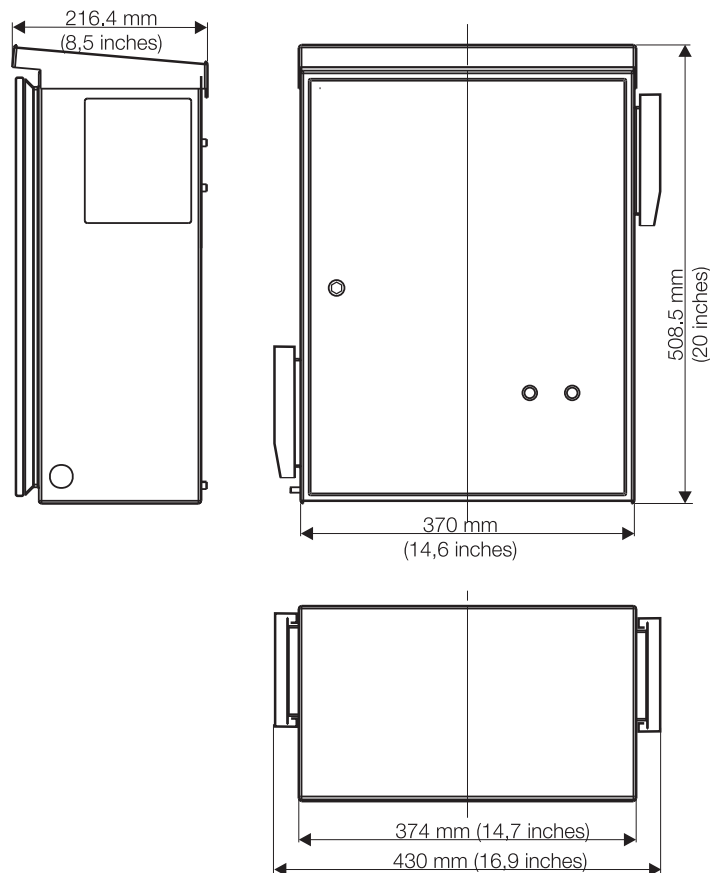
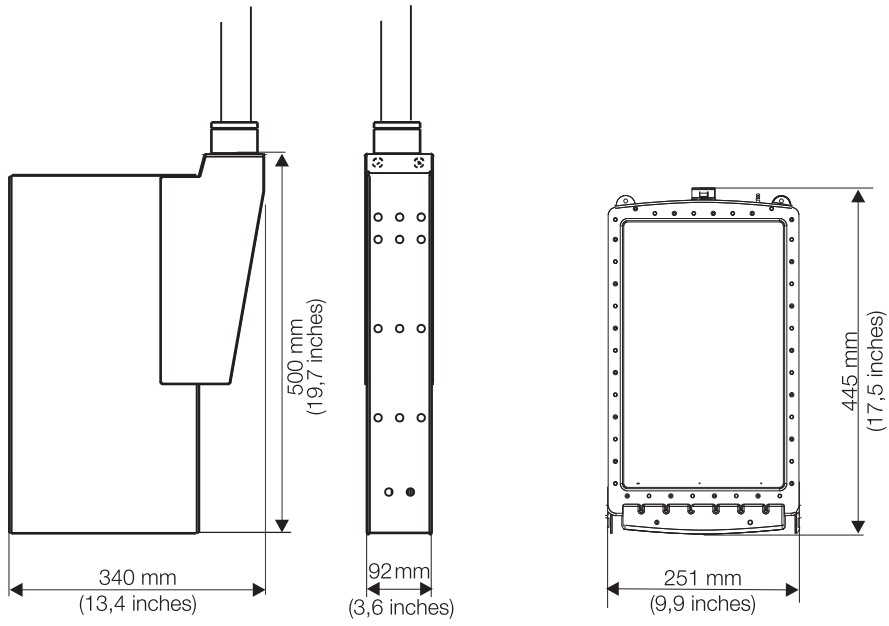
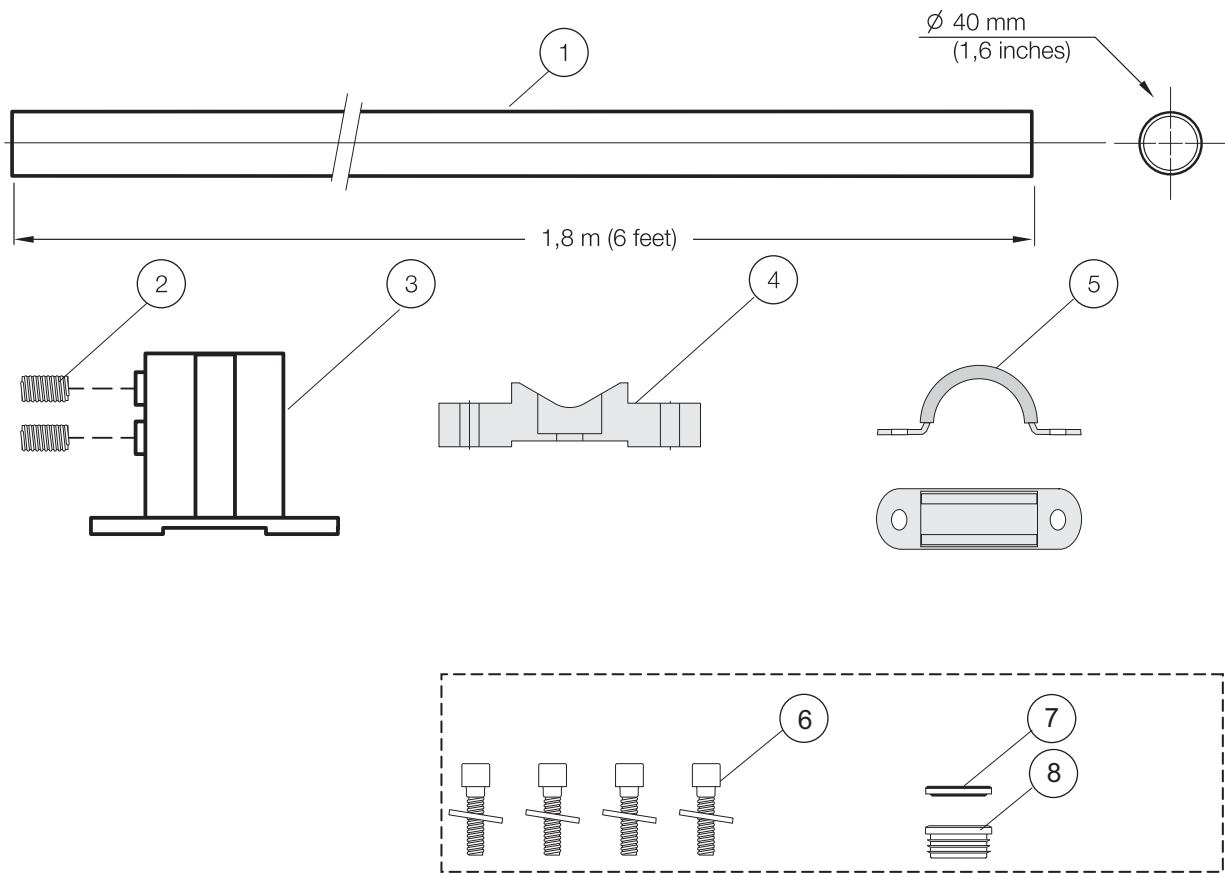

Fig. 3-9 Module carrier and filter module



Installation

Fig. 3-10 Control unit bracket components



1. HRO304 supporting pipe 1.8 m	Included in hardware LZX416: 6. Cheese head bolt M8 x 16 (4) 7. Blanking plug 8. Plug
2. Setscrew M8 x 10 (2) in LZX416	
3. LZY827 base	
4. HHH277 bracket (2)	
5. EHK063 pipe clamp (2)	

3.2 Installing control unit with control unit bracket LZX676

Fig. 3-11 Installation of control unit bracket

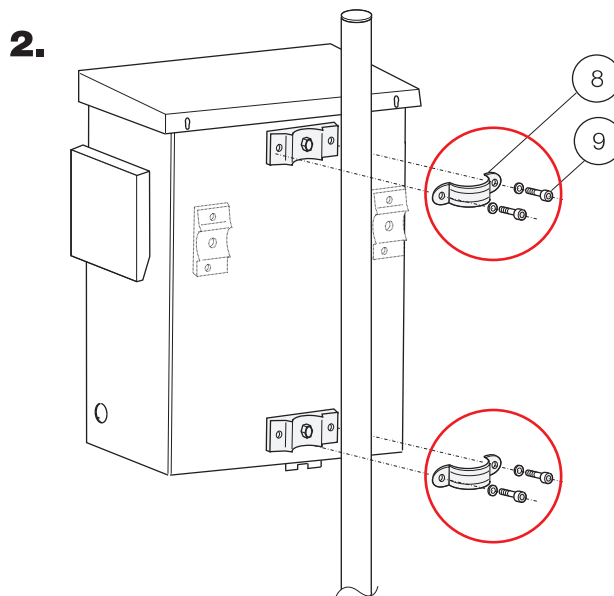
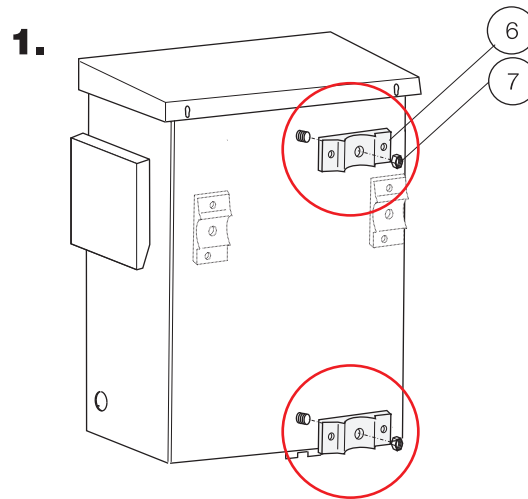
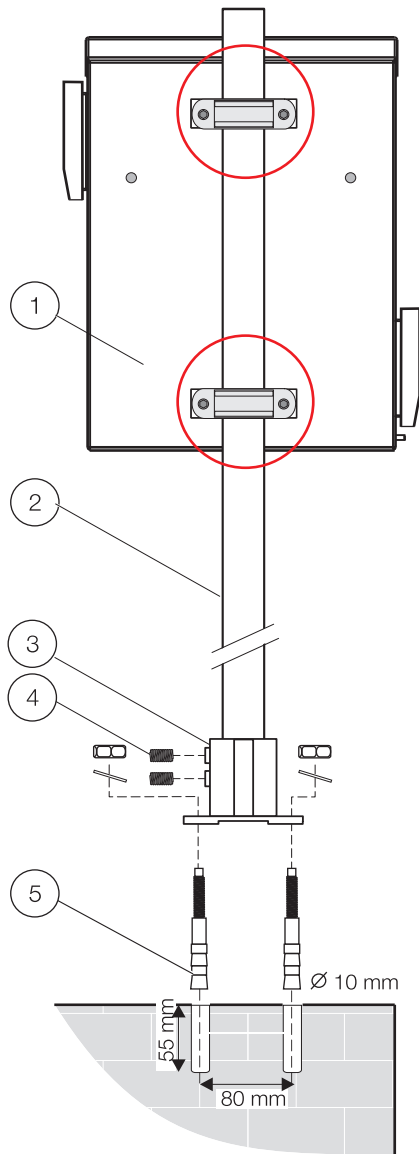

1. Rear of control unit	6. Bracket (2)
2. Supporting pipe 1.8 m	7. Nut M8 (2)
3. Base	8. Pipe clamp (2)
4. Setscrew M8 x 10 (2)	9. Cheese head bolt M8 x 16 (2) + washer (2)
5. Anchor (4)	

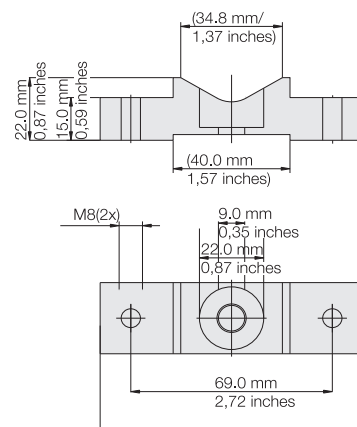
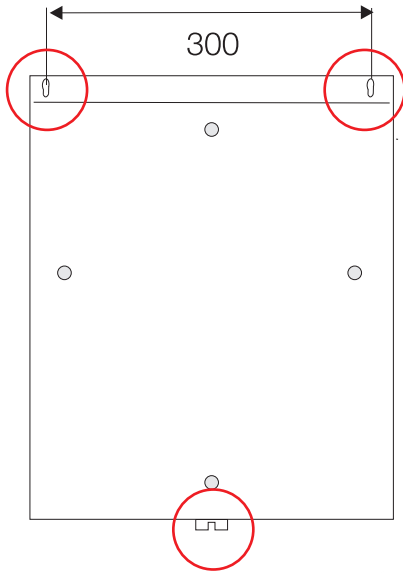

Fig. 3-12 Installation on a wall (hole diagram)



Procedure:

1. Make the two upper holes.
2. Use wall plugs and screws from the accessory set.
3. Fit instrument.
4. Mark third hole at the bottom and make hole.
5. Fit instrument.

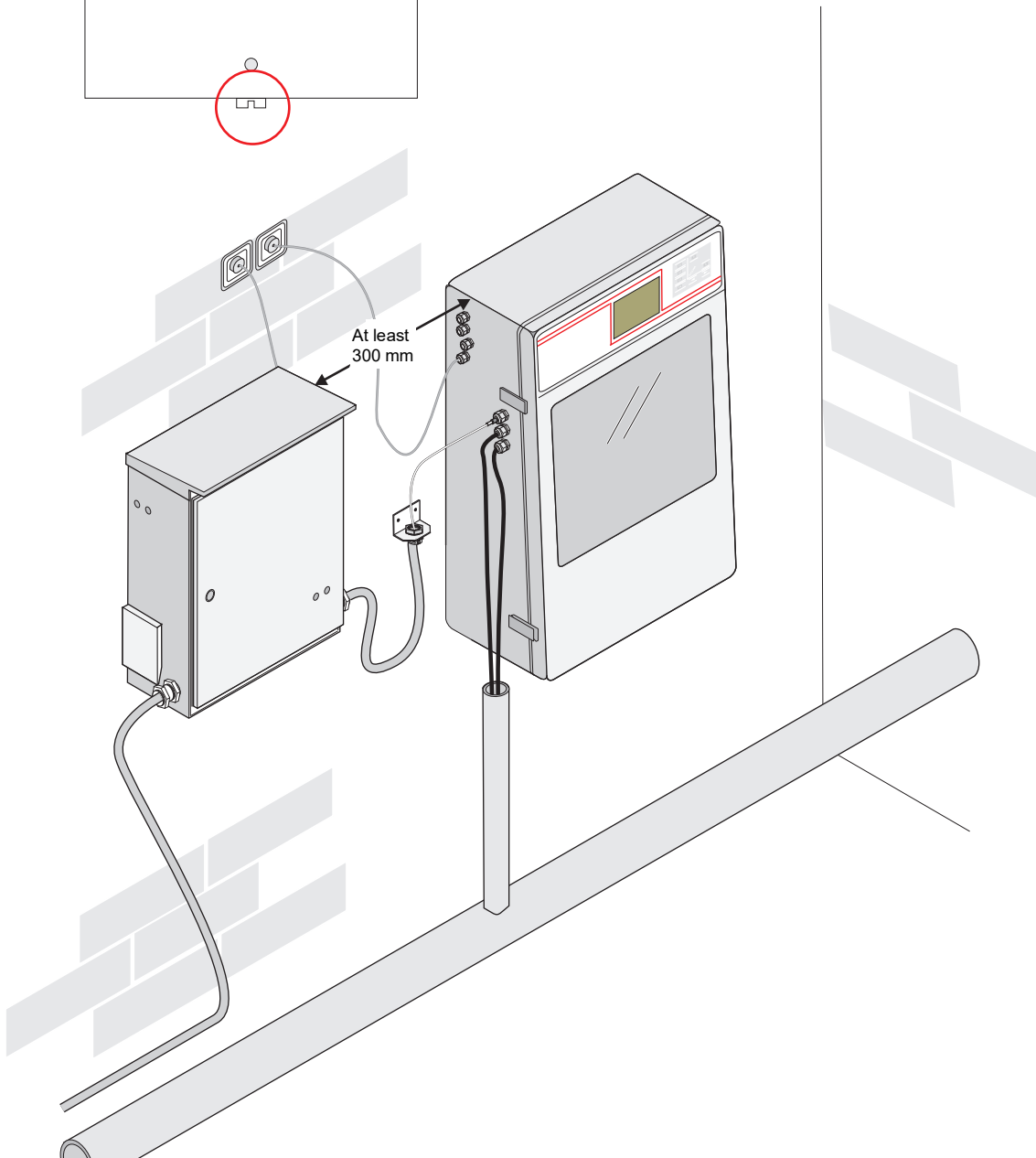
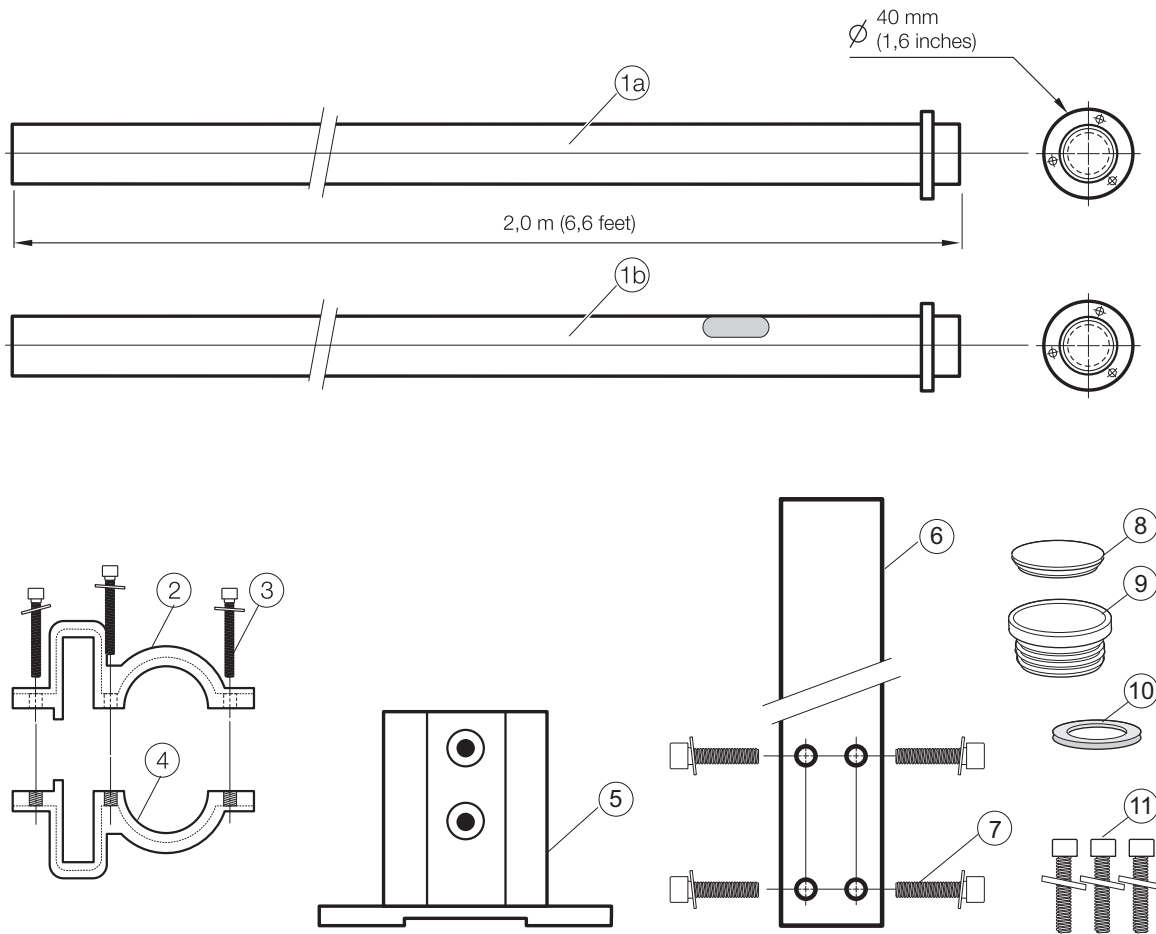
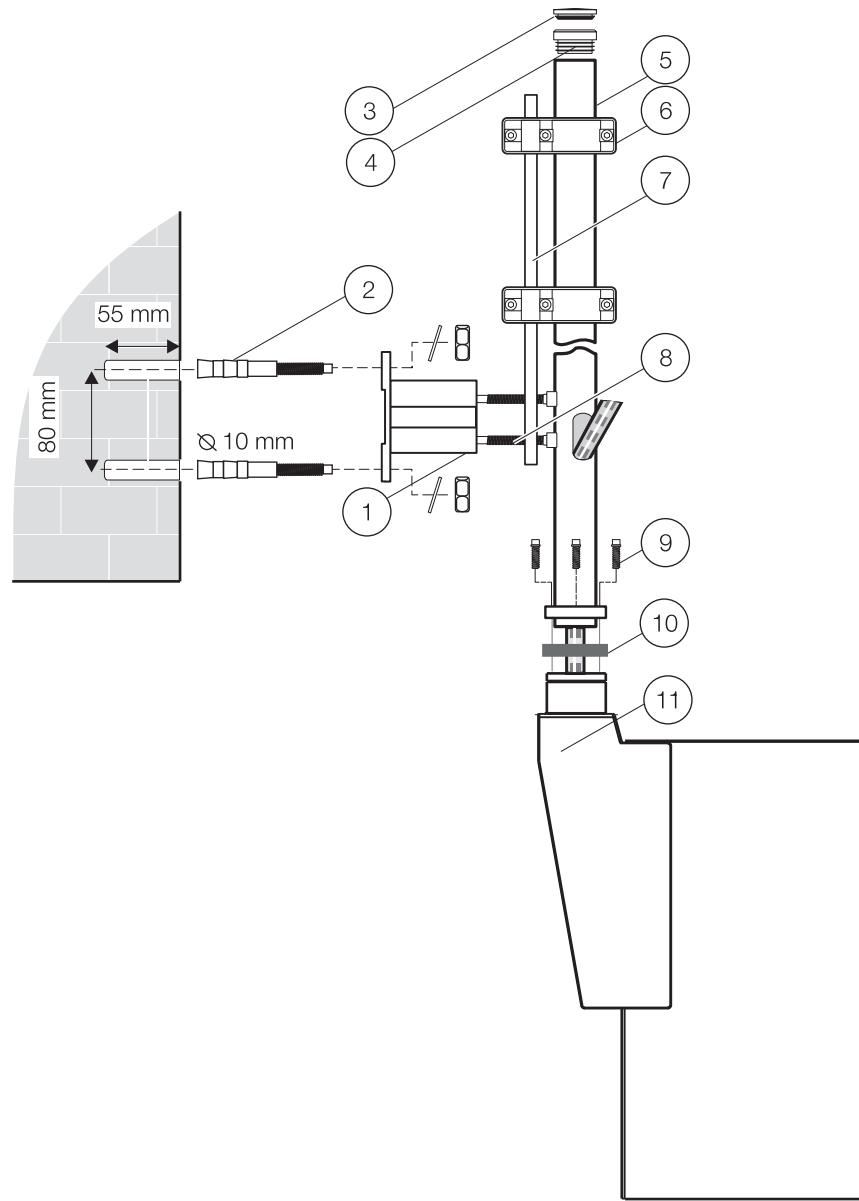

Fig. 3-13 Components for the module carrier bracket



<p>1. (a) LZY714.99.00020 mounting pipe 2.0 m for LZY714.99.43020 (b) LZY714.99.00050 mounting pipe 2.0 m with slot on side for LZY714.99.43050</p>	<p>6. LZY804 fastening lug</p>
<p>Included in retaining clamp LZY449: 2. Clamp half (1) 3. Cheese head bolt M5 x 20 (3) 4. Clamp half with thread (1)</p>	<p>Included in hardware LZX416: 7. Cheese head bolt M8 x 40 8. Blanking plug 9. Plug</p>
<p>5. LZY827 base</p>	<p>Included in hardware LZX417: 10. Flat seal Included in hardware LZY362: 11. Cheese head bolt M5 x 12 (6)</p>

Fig. 3-14 Installation of module carrier



1. Base	7. Fastening lug
2. Anchor (4)	8. Cheese head bolt M8 x 40
3. Blanking plug	9. Cheese head bolt M3 x 10 (6)
4. Plug	10. Flat seal
5. Mounting pipe 2.0 m for LZY714.99.43020 or mounting pipe 2.0 m with slot on side for LZY714.99.43050	11. Module carrier
6. Retaining clamp	

3.3 Connecting tubes

Fig. 3-15 Preparation of suction tube connection

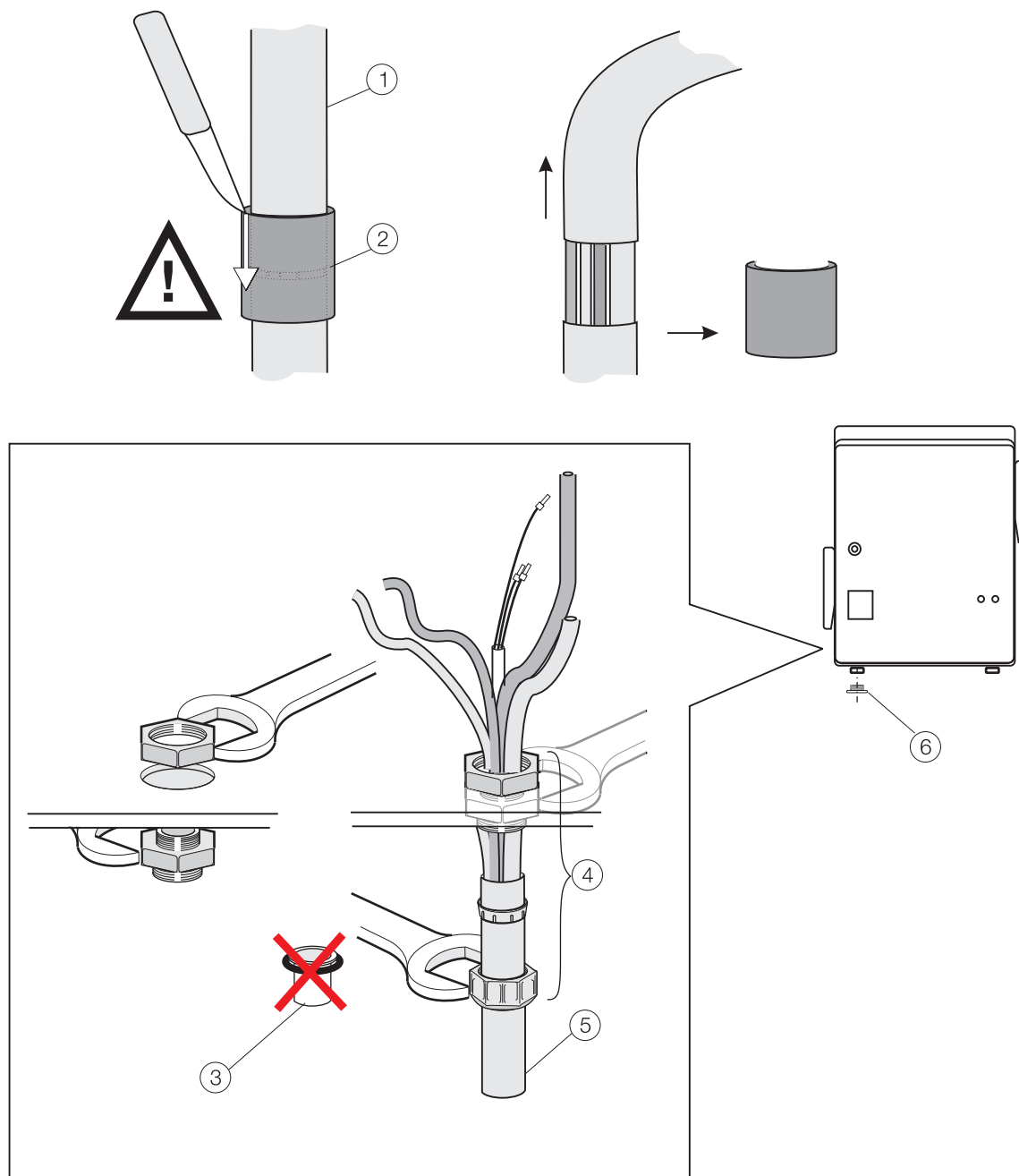

1. Protective tube (transport protection)	4. Cable gland M20 x 1.5
2. Shrink tube	5. Suction tube
3. Metal sleeve	6. Blanking plug

Fig. 3-16 Preparation of sample tube connection

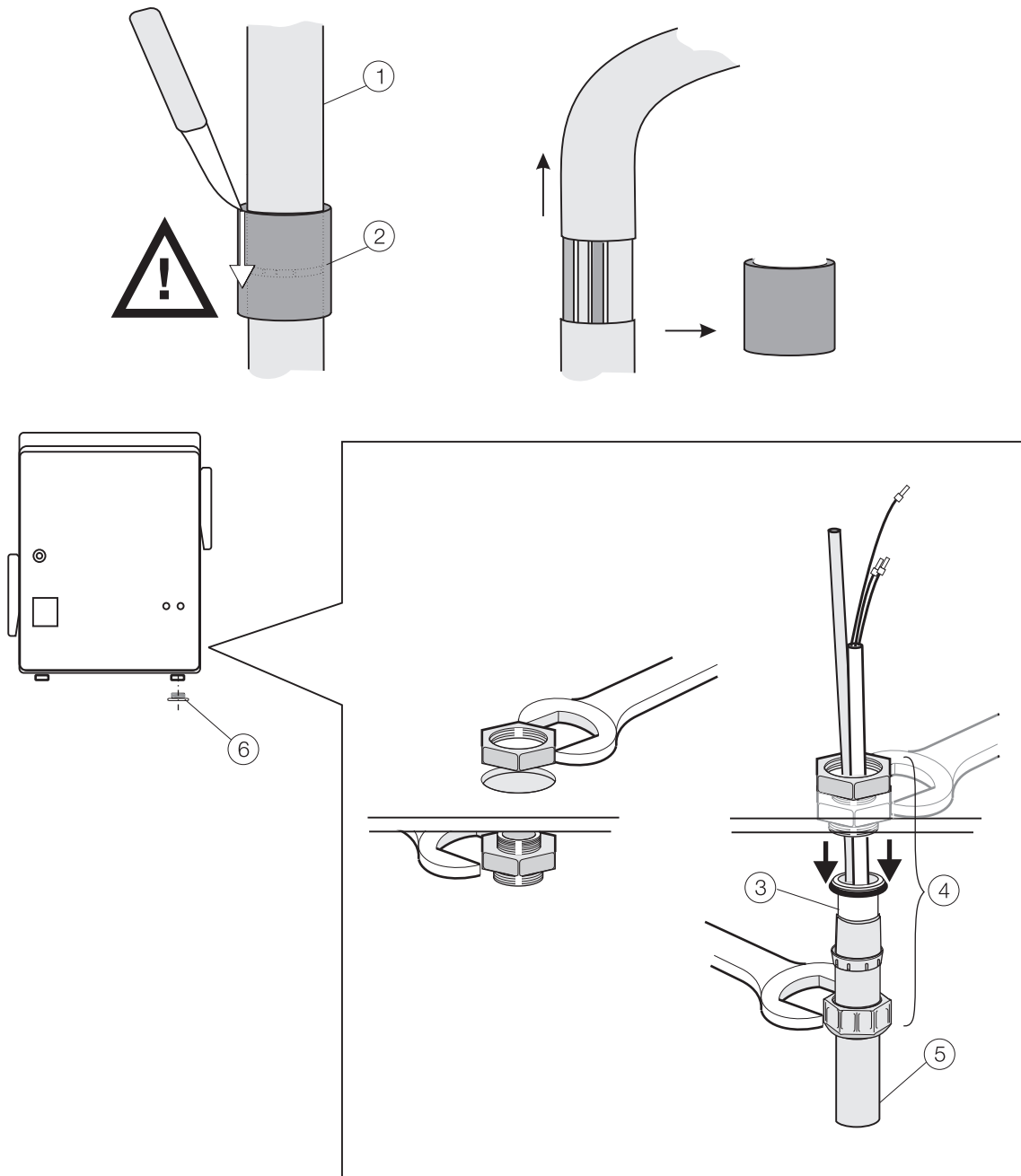

1. Protective tube (transport protection)	4. Cable gland M20 x 1.5
2. Shrink tube	5. Suction tube
3. Metal sleeve	6. Blanking plug

Fig. 3-17 Layout of suction tube

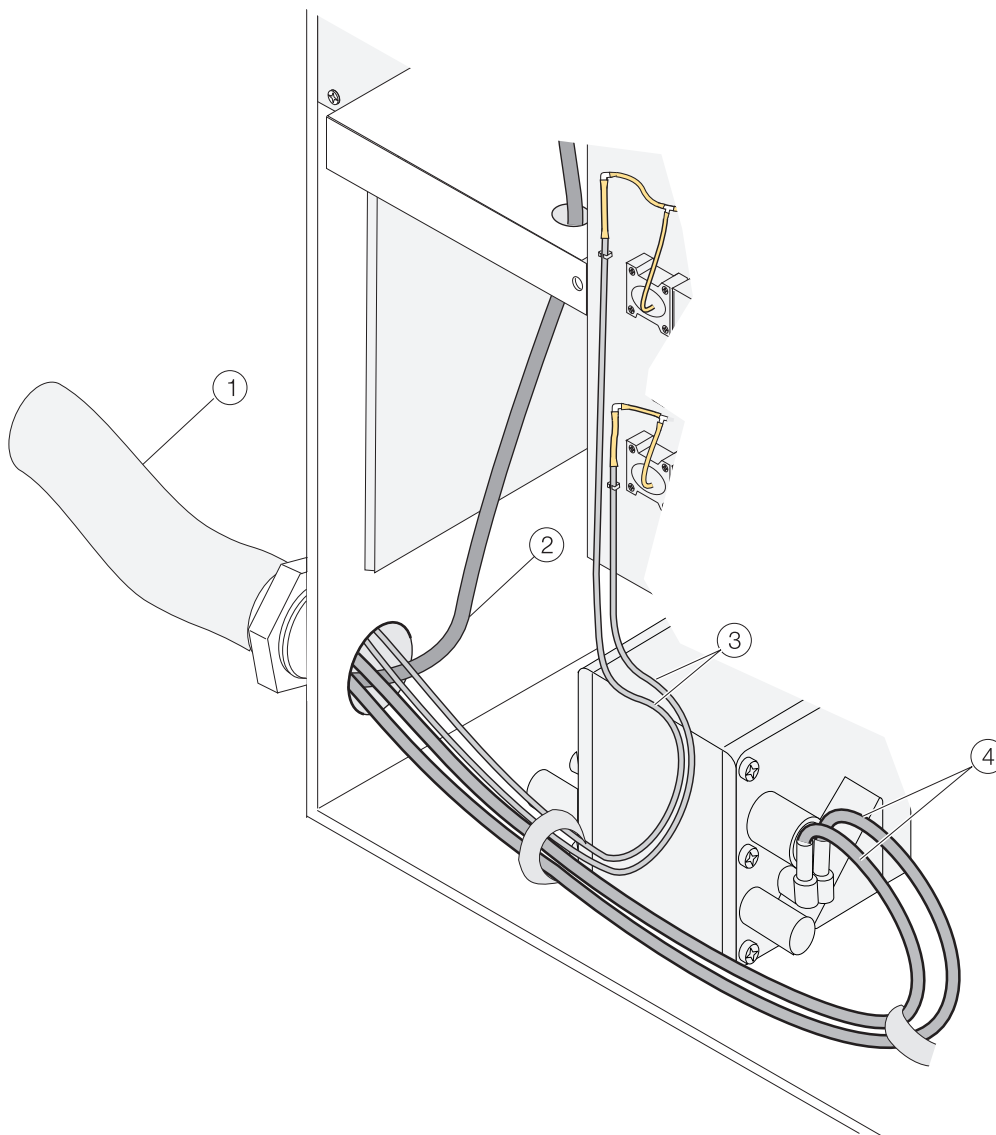

1. Suction tube	4. Air tubes
2. Pipe heater connecting cable	5. Clip
3. Sample suction tubes	

NOTICE

The tubes must be laid with the aid of the clips such that they cannot chaff due to the vibration from the compressor!

Note: the sample pressure tube (1) is pushed through the flowmeter from below and fastened to the 90° fitting (3). The fixing screw (2) is then tightened lightly.

Fig. 3-18 Laying sample tube

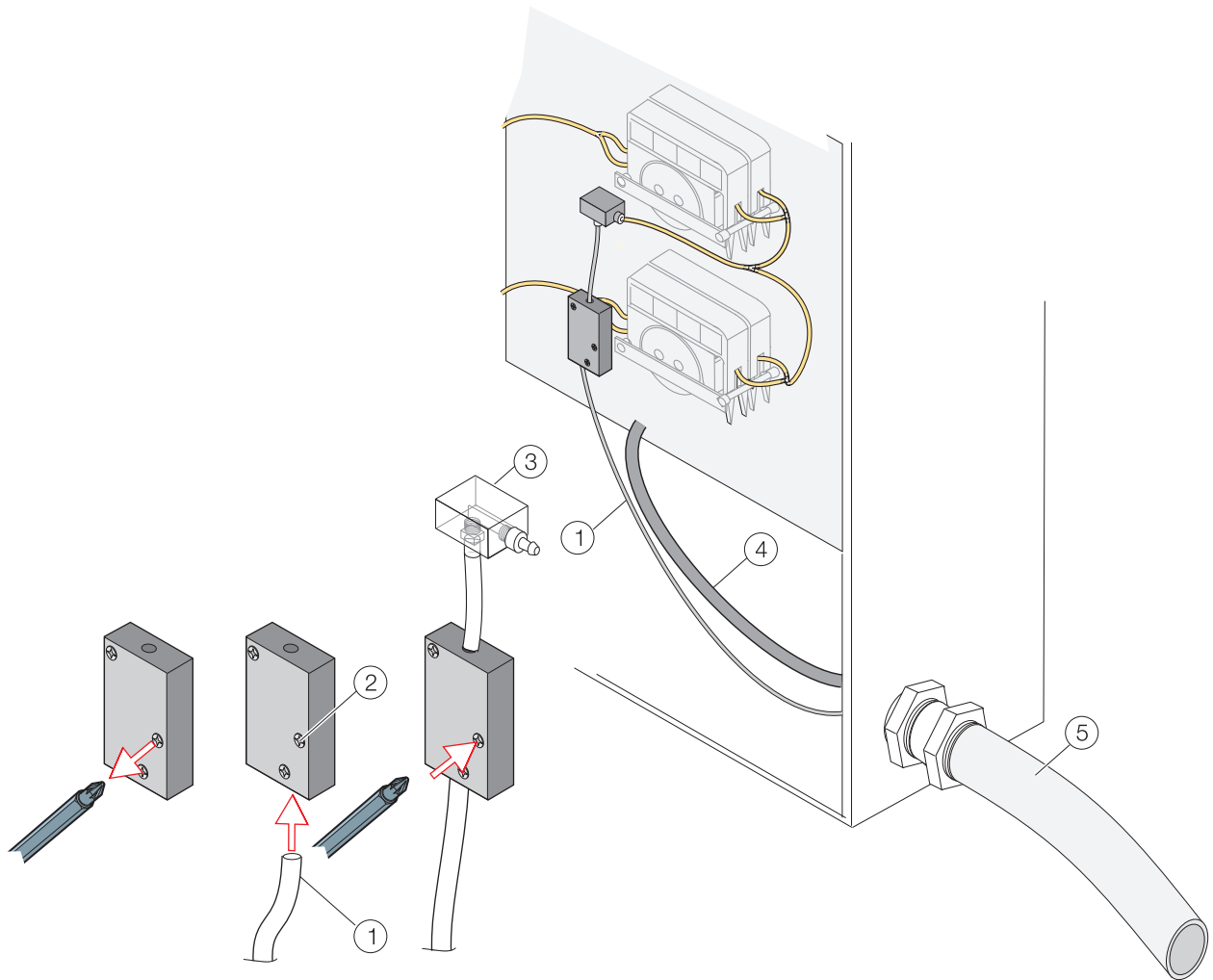

1. Sample pressure tube	4. Pipe heater connecting cable
2. Fixing screw	5. Sample tube
3. 90° fitting	

Fig. 3-19 Tube diagram

Note: always ensure that the tubes are laid correctly! The filter modules may be damaged if sample is pumped back via the sample suction tubes (1)+(2)!

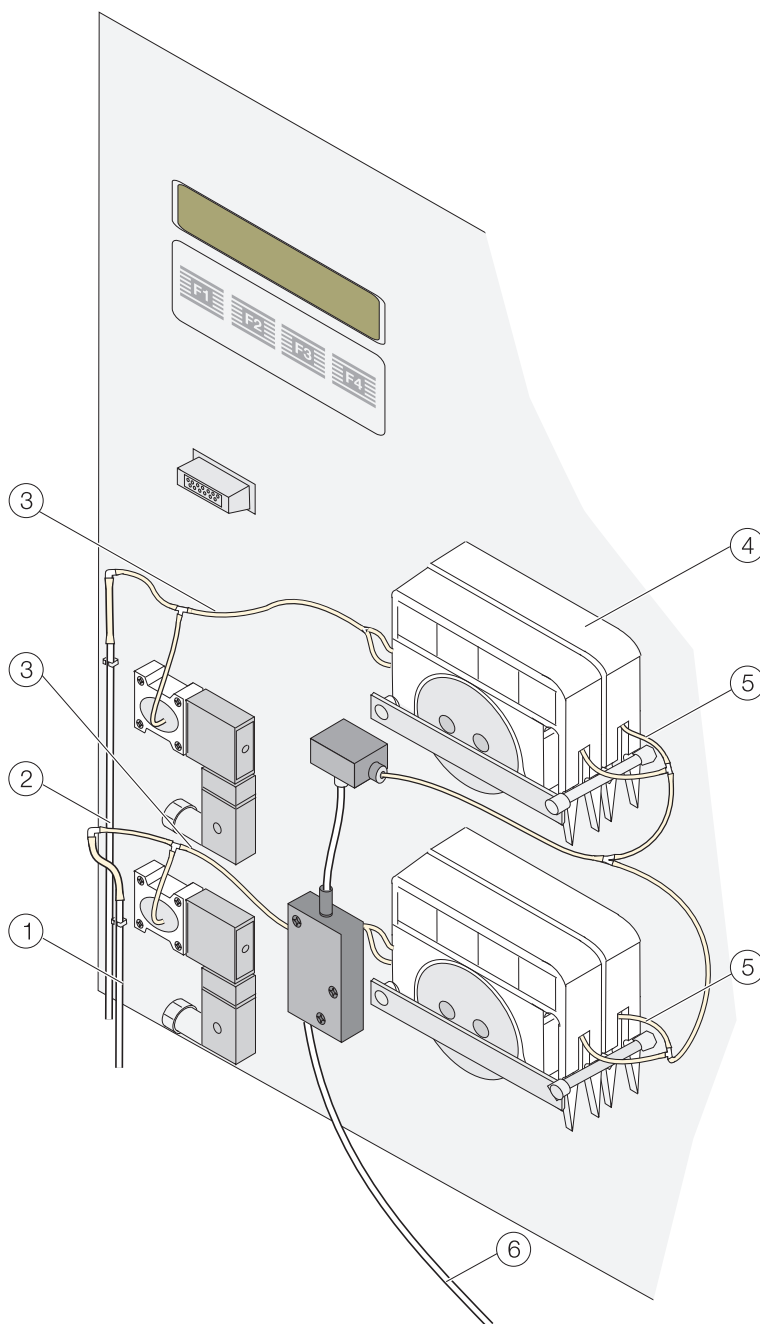

1. Sample suction tube, filter module A or B	4. Pump cartridges
2. Sample suction tube, filter module A or B	5. Metering tube
3. Connecting tube	6. Sample pressure tube

3.4 Electrical connections

NOTICE

Use only earthed sockets for the connection of this device to the power supply. If it is not clear whether the sockets are earthed, have this checked by a qualified electrician.

In addition to supplying power, the power plug also serves to isolate the device quickly from the mains where necessary.

The entire measurement system has two power plugs (measurement device and control unit). During the disconnection from the mains, it must be made sure that the correct power plug is pulled (e.g. labeling of the sockets).

This is recommended for long-term disuse and can prevent potential dangers in the event of a fault.

Therefore make sure that the sockets to which the device is connected are easy to reach by each user at all times.

NOTICE

On removal of the power plug (fixed installation of mains supply lead), a suitable bipolar circuit breaker must be installed!

NOTICE

Pull out the power plug before opening the device.

⚠ WARNING

Only qualified experts may perform the tasks described in this section of the manual, in compliance with all locally applicable safety regulations.

Fig. 3-20 Terminal assignments

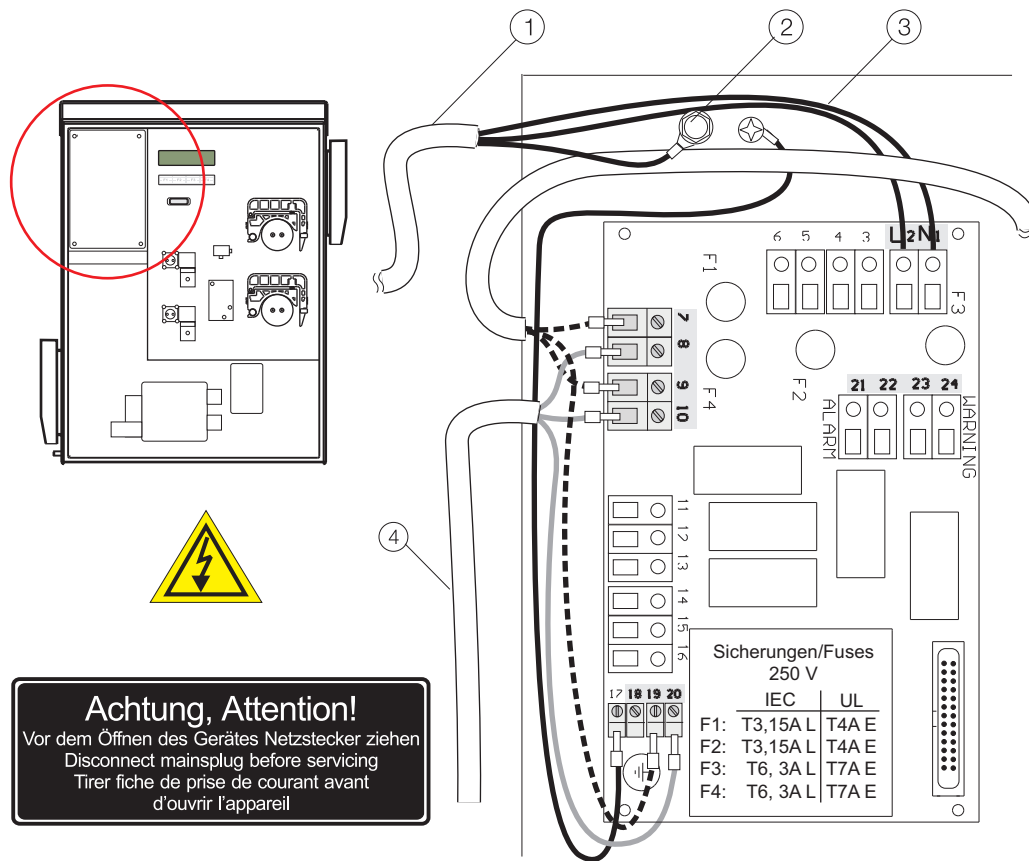

1. Mains cable (power supply)	3. Heater connecting cable, sample tube
2. Earth connection	4. Heater connecting cable, suction tube

NOTICE

Route the signal lines (21, 22, 23, 24) separated from the power cable.

Table 3-1 Terminal assignments

Terminal no.	Connection
1	N (230 V AC / 50-60 Hz, option: 115 V AC)
2	L (230 V AC / 50-60 Hz, option: 115 V AC)
7	N (sample tube heater)
8	N (suction tube heater)
9	L (sample tube heater)
10	L (suction tube heater)
18	Earth for screening signal wires
19	Earth for suction tube heater
20	Earth for sample tube heater
21/22	Floating fault signalling contacts (normally open)
23/24	Floating warning contacts (normally open)

3.5 Connection to process instruments

The filtered sample passes through the sample pressure tube inside the sample tube to the process instruments connected.

The bracket enables the sample tube to be fastened to a wall at a distance of approx. 200 mm from the process instrument.

Fig. 3-21 Mounting bracket

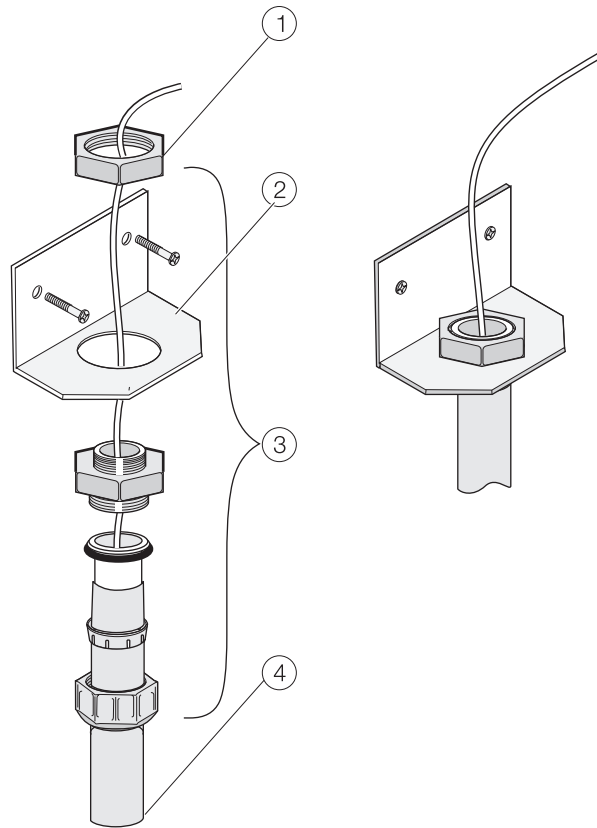

1. Sample pressure tube	3. Cable gland M20 x 1.5
2. Bracket	4. Sample tube

Fig. 3-22 Connection of sample pressure tube

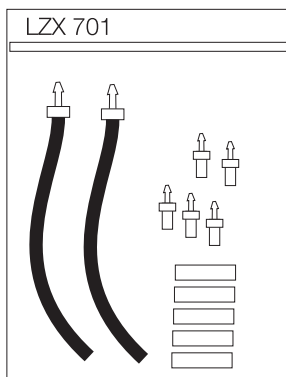

All the adapters necessary to the direct connection of the sample pressure tube to the sample feed openings on the process instruments are supplied in the tube adapter set LZX701 supplied.

If several instruments are supplied from one FILTRAX, the sample must be provided from the first instrument to the next using the 2/4 tube to ensure a short time delay.

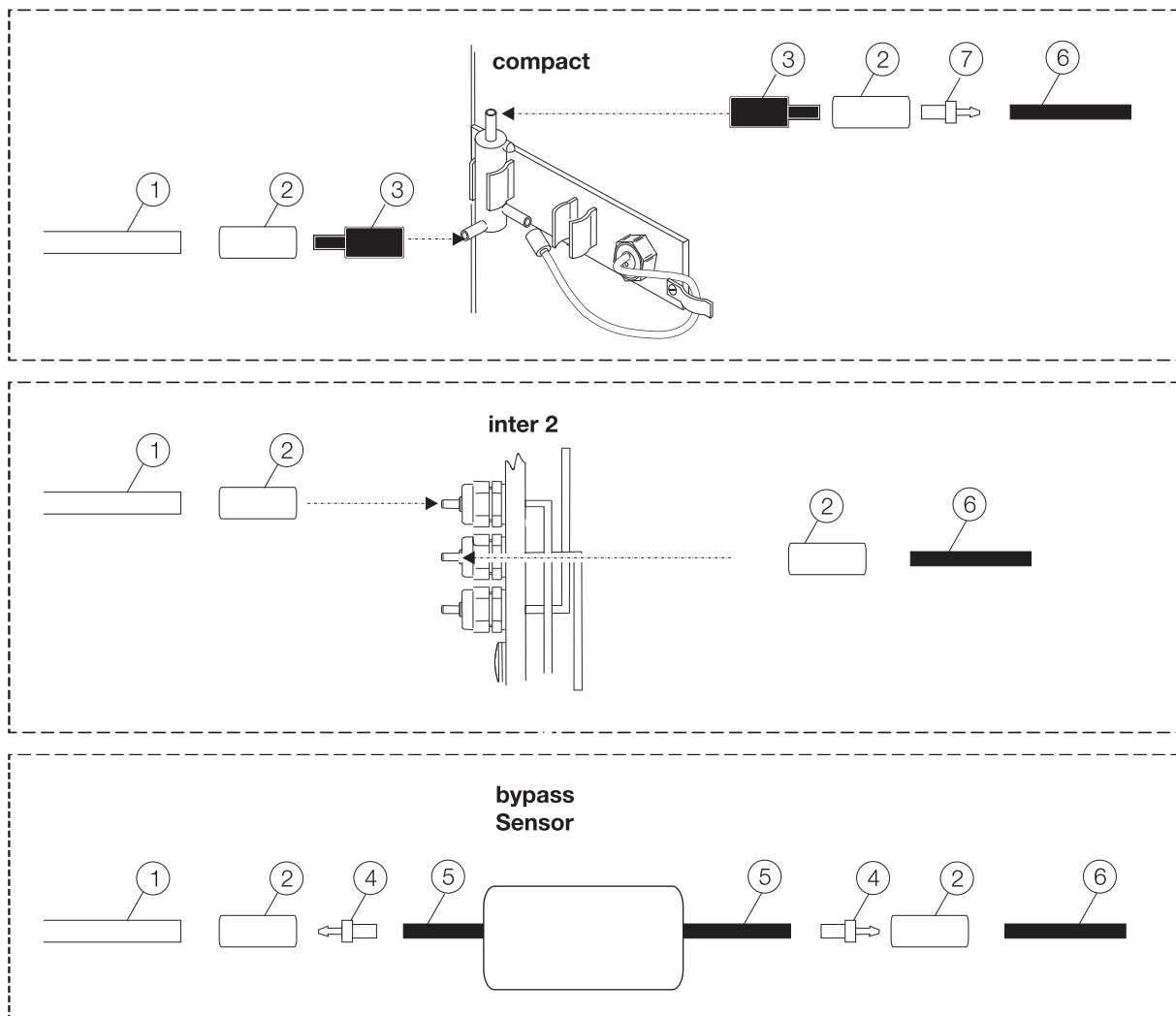

1. FILTRAX sample pressure tube	5. 4/6 tube
2. Sleeve	6. 2/4 tube
3. Quick-release connector	7. Small fitting
4. Large fitting	

4.1 Placing instrument in operation

NOTICE

The sample pressure tube must never be clamped such that it is blocked off - the pressure build up would either result in damage to the tubes or the tube connections would spring off!!

After assembly has been completed, you can place FILTRAX in operation. For this purpose

1. Clip pump cartridges into the control unit
2. Unpack the two filter modules and carefully slide into the module carrier!

NOTICE

As far as possible do not touch the delicate filter membrane!

3. Fit the two thicker sample tubes and the two thinner air tubes to tube fittings of appropriate size as per the figure
4. Plug into the mains and set instrument parameters (sec. 5 Software menu system)

Fig. 4-23 **Inserting filter modules**

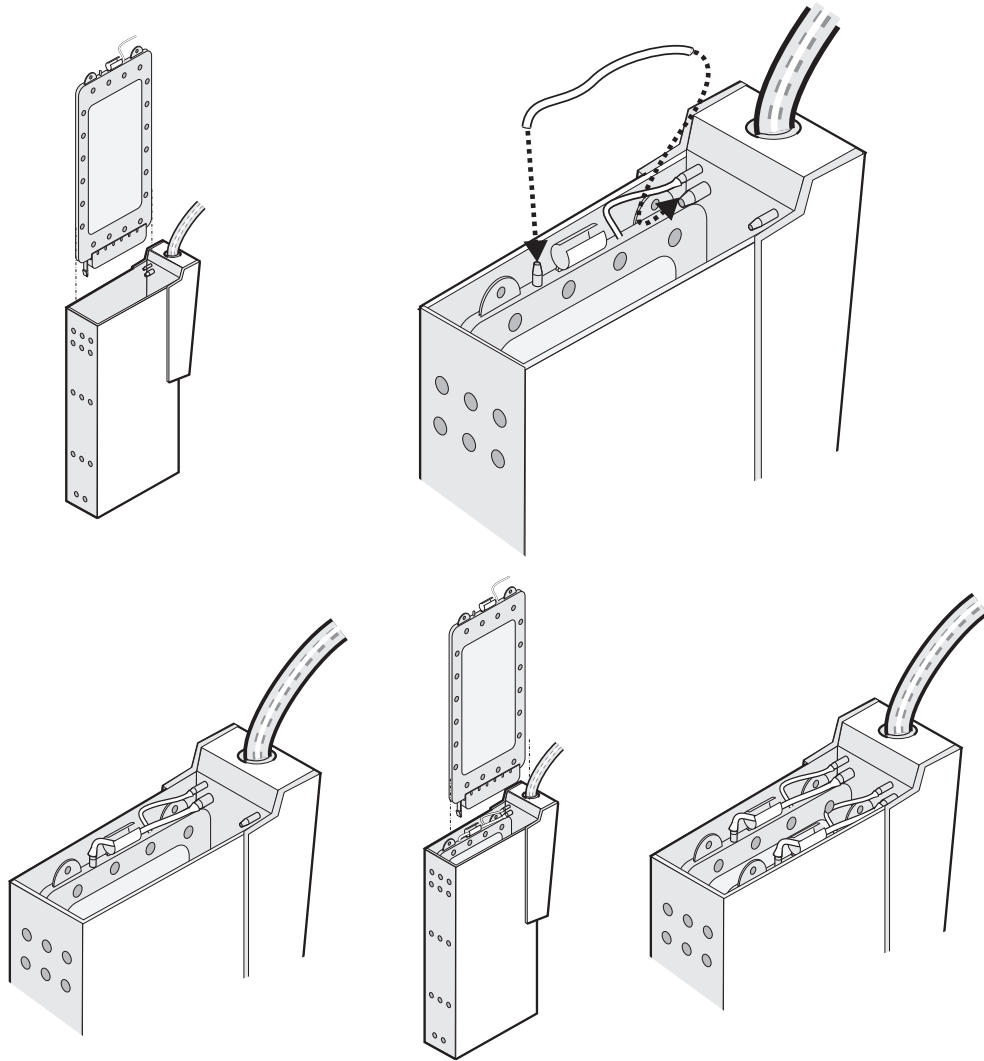

4.2 Taking instrument out of operation

4.2.1 Filter modules

If the instrument is to be taken out of operation for an extended period, you should clean the filter modules (sec. 6 Maintenance) and then protect against drying out. For this purpose 4 plastic bags are supplied.

Fig. 4-24 Plastic bag

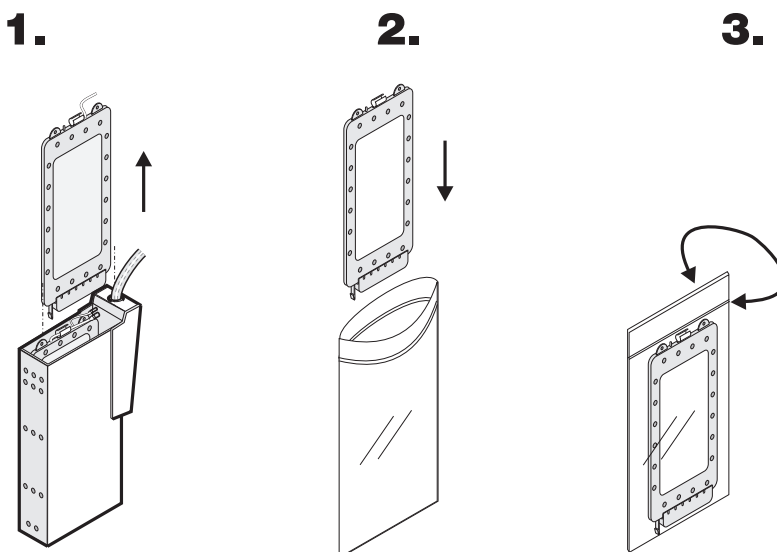

4.2.2 Control unit

On installation outdoors, the control unit should always be in operation so that the temperature control can provide protection against overheating or freezing. When the instrument is taken out of operation, the [+SERVICE] menu is opened or the control unit removed:

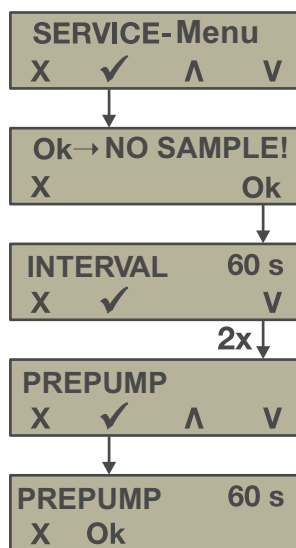

- Prior to dismantling open the [+SERVICE] menu and remove suction and sample tube
- Select [PREPUMP] command and leave the internal tubes to empty
- Then open [+SERVICE] menu again, release tension on pump cartridges and unplug from the mains

5.1 Using the keypad

All functions in the instrument are software-controlled. Operation is via menus using the four keys below the display. The current sample volumes (1) for the two filter modules and the operating state of the heating (2) can be seen on the display during operation. To reach the menu level of the program, one of the four function keys F1-F4 (3) must be pressed for 3 seconds.

The significance of the keys on the menu appears (sensibly abbreviated) in the second line on the display (softkey function):

- X** = Cancel
- ✓** = Change the setting
- Λ** = Back to the previous command
- V** = Continue to the next command

Fig. 5-25 **Display**

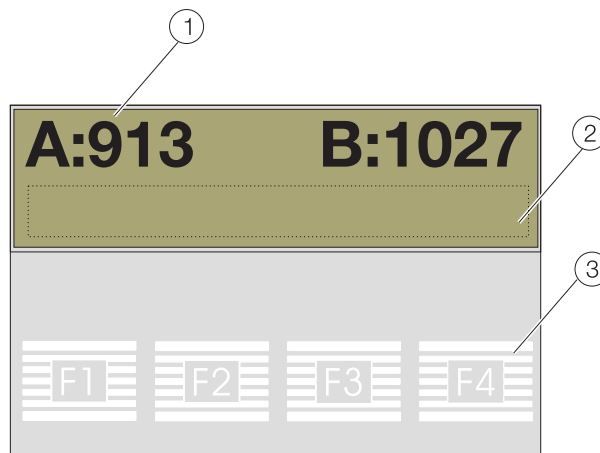

1. Current sample volume (approx. ml/h)	3. Function keys
2. Operating state of the heating, alternatively: messages, warnings, faults	

5.2 Menu overview

Menu level 1	Menu level 2
+DEVICEDATA For setting the instrument parameters	ΔCONTRAST
	LANGUAGE
	HEATER
	HEAT.START
	HEAT.STOP
	WARNING<
	FAULT<
	DATE
	TIME
	PASSWORD
	SW-VERSION
	SW-CO.PROC.
+SIGNALS For checking internal data in case of service	MODUL A
	MODUL B
	TEMPERATURE (control unit)
	AMPL.
	MEAS-Z
	MEAS
	MEAS-F
+SERVICE For maintenance and function tests	INTERVAL
	EXTRACTION
	PREPUMP
	FILTERCLEANING
	+OP.COUNTERS (display and reset)
	+TEST OF FUNCT.
	+SIGNALS
	+DEVICEDATA
	STATUS (output of detailed error messages and acknowledgement)
+OP.COUNTERS (display only)	CLEANED
	MODUL A
	MODUL B
	PUMPTUBES
	PUMPCASSETTES
	PUMPWHEELS
	AIRFILTER COMPRESSOR
	AIRFILTER CASE
	COMPRESSOR

5.3 [+DEVICEDATA] menu

Instrument parameters for adaptation to the related conditions.

Note: While the instrument is in this menu, sample pumping continues. If a key is not pressed for longer than ten minutes, the instrument automatically returns to the display of the data on operation.

MENU	
Command	
Setting	Description
+DEVICEDATA	

△CONTRAST		
	-90 to +90	<i>Reading angle for the display</i>
LANGUAGE		
	D, GB, NL, F, I, E, PL, S	
HEATER		
	ON, OFF, TIMER (time control) Default setting: TIMER	<i>Operation of the tube heaters</i>
HEAT.START (only for [HEATER]:TIMER)		
	JAN to DEC, Default setting: OCT	<i>Activation of the heater at the start of the month selected</i>
HEAT.STOP (only for [HEATER]:TIMER)		
	JAN to DEC, Default setting: MRZ (March)	<i>Deactivation of the heater at the end of the month selected</i>
WARNING<		
	200...800 ml/h in 10 ml steps	<i>Warning relay contact* set when the sample volume drops below the amount set</i>
FAULT<		
	100...600 ml/h in 10 ml steps	<i>Fault relay contact* set when the sample volume drops below the amount set</i>
DATE		
	Setting for the date	
TIME		
	Setting for the time	
PASSWORD		
	4-digits with numbers 1-4	<i>Password protection on activation</i>
SW-VERSION		
	Only for information	<i>Version of the instrument software</i>
SW-CO.PROC.		
	Only for information	<i>Version of the coprocessor software</i>

*If the power supply is interrupted (power failure) both relay contacts are closed.

5.4 [+SIGNALS] menu

The [+SIGNALS] menu is used for service and inspection by the manufacturer. It is not needed for operation and the instrument settings.

Note: While the instrument is in this menu, normal operation continues. If a key is not pressed for longer than ten minutes, the display automatically returns to the display of the data on operation.

MENU	
Command	Description

+SIGNALS	
MODUL A	
	<i>Parameter for the flow rate in module A (single measurement), approximately corresponds to a sample volume in ml/h</i>
MODUL B	
	<i>Parameter for the flow rate in module B (single measurement), approximately corresponds to a sample volume in ml/h</i>
TEMPERATURE (housing)	
	<i>Temperature in the control unit in °C or °F</i>
AMPL.	
	<i>Photometer gain</i>
MEAS-Z	
	<i>Level of the last valid zero measurement</i>
MEAS	
	<i>Level of the last valid flow rate measurement</i>
MEAS-F	
	<i>Current measured level</i>

5.5 [+OP.COUNTERS] menu

The [+OP.COUNTERS] menu provides information on the duration of the use of the various instrument components and consumables. It is not needed for operation and the instrument settings.

Note: While the instrument is in this menu, normal operation continues. If a key is not pressed for longer than ten minutes, the display automatically returns to the display of the data on operation.

MENU	
Command	Description
+OP.COUNTERS	
CLEANED	Month when cleaning was last performed, is automatically updated during [+FILTERCLEANING]
MODUL A	Operating time for filter module A in days
MODUL B	Operating time for filter module B in days
P.TUBES IN	Remaining operating time for both pump tubes in days (91 - 0 - negative number*)
P.CARTR.IN	Remaining operating time for both pump cartridges in days (365 - 0 - negative number*)
P.ROLL.IN	Remaining operating time for pump rollers in days (365 - 0 - negative number*)
AIR F.C.IN	Remaining operating time for the compressor air filter in days (365 - 0 - negative number*)
AIR F.H.IN	Remaining operating time for the two air filters in the control unit in days (91 - 0 - negative number*) - it is not necessarily imperative to change the air filter on the air outlet side so frequently
COMP. IN	Remaining operating time for the compressor in days (730 - 0 - negative number*)

*If replacement date passed.

5.6 [+SERVICE] menu

Important Note: All maintenance and service work apart from pure visual inspection must be performed with the instrument in this menu!

When this menu is opened, initially the message "OK - NO SAMPLE!" appears to indicate that on the activation of this menu, sample feed to the measuring instruments is interrupted immediately! Operation is only re-started when this menu is actively left using the keypad or a program that is opened.

If this menu is selected, then

- The pumps are stopped immediately
- The filter module venting is shut down
- The red signal lamp is illuminated
- The fault relay is set
- Only the temperature control and heater systems in the control unit and the tubes remain active

The functions of the individual commands and sub-menus ([FILTERCLEANING], [OP.COUNTERS], [+TEST OF FUNCT.]) are explained in detail in section 6 Maintenance and section 7 Faults, causes, rectification. They are not required for normal operation.

MENU		
Command		
Setting	Description	
+SERVICE		
INTERVAL		
30...300 s (default setting 60 s)	Changeover interval for sample pumping between module A and B	
EXTRACTION		
50...130% (default setting 100% = 900 ml/h - this sample volume is produced on correct installation under normal operating conditions with clean filter modules)	The volume pumped by the pumps is adjusted via the speed of the pumps	
PREPUMP		
	For filling all tubes both pumps are operated simultaneously for 10 min. The venting of the filter modules remains active - operation is then re-started automatically	
FILTERCLEANING		
	Menu-based cleaning of the filter modules, detailed description in sec. 7.2 Maintenance - after each clean the date of the operating counter [CLEANED] is automatically updated and operation re-started	
PHOTOMETER		
ON/OFF	Flow rate measurement can be switched on and off	

Operation

MENU		
Submenu		
Command	Description	
+SERVICE		
+OP.COUNTERS		
	<i>Open [+OP.COUNTERS] menu - all counters can now be reset</i>	
+TEST OF FUNCT.		
Component	Possible selections	<i>Every component listed can be operated and tested individually</i>
compressor	on, off	
pump a	(back and forward every 3 s), stop	
pump b	(back and forward every 3 s), stop	
housing fan	on, off	
hous. heater	on, off	
heater tubes	on, off	
warning	on, off	
malfunction	on, off	
sensor a	volume measurement a	
sensor b	volume measurement b	
airvalve a	op., cl.	
airvalve b	op., cl.	
signallamps	on, off (green/red simultaneously)	
+SIGNALS		
	<i>Open [+SIGNALS] menu</i>	
+DEVICEDATA		
	<i>Open [+DEVICEDATA] menu</i>	
STATUS		
	<i>Detailed fault description and acknowledgement</i>	

The manufacturer recommends taking out a service contract. This contract extends the warranty to 5 years and ensures that all inspection and maintenance work is performed by qualified personnel.

The maintenance to be performed by the user is then limited to regular visual inspections, replacing consumables and cleaning, if necessary.

Maintenance Schedule		FILTRAX DOC273.52.04006.Jul03	
Number:	Place of sampling:		
Installation Date:	by:		
Inspection and Maintenance as part of the Service Contract		Maintenance by the User	
Every 12 months Replace <ul style="list-style-type: none"> ♦ Air Filter (Compressor) ♦ Pump Cartridges ♦ Pump Rollers ♦ Connecting Tubes 	Every 6 months Check <ul style="list-style-type: none"> ♦ Air Filter (Compressor) ♦ Pump Cartridges ♦ Pump Rollers ♦ Connecting Tubes ♦ Filter Module ♦ Electronics 	Every 3 months Replace <ul style="list-style-type: none"> ♦ Pump Tubes ♦ Air Filter (Control Unit) Clean <ul style="list-style-type: none"> ♦ Filter Module (if/as necessary) ♦ Sample Tubes (if/as necessary) 	Weekly Visual Inspection <ul style="list-style-type: none"> ♦ Sample Quality ♦ Device Function ♦ Air Filter (Control Unit)
Every 24 months Replace <ul style="list-style-type: none"> ♦ Compressor 			

6.1 Maintenance work

The reliable and correct operation of this sample conditioning system can only be ensured if the maintenance work is performed regularly as per the maintenance calendar.

The necessary consumables are supplied or included in the set of annual consumables.

NOTICE

The sample pressure tube must never be clamped such that it is blocked off - the pressure build up would either result in damage to the tubes or the tube connections would spring off!!

6.1.1 Weekly

Visual inspection

- General instrument function
- Function of the venting on the filter modules
- Quality of the filtered samples
- State of the air filter in the control unit

6.1.2 Every 3 months



All maintenance work must be performed in the [+SERVICE] menu!

Replacement of consumables and cleaning

- Replacement of the metering tubes
- Replacement of control unit air filter (depending on condition only air inlet)
- Menu-based cleaning (this cleaning interval can vary depending on the conditions)

Fig. 6-26 Consumables after 3 months

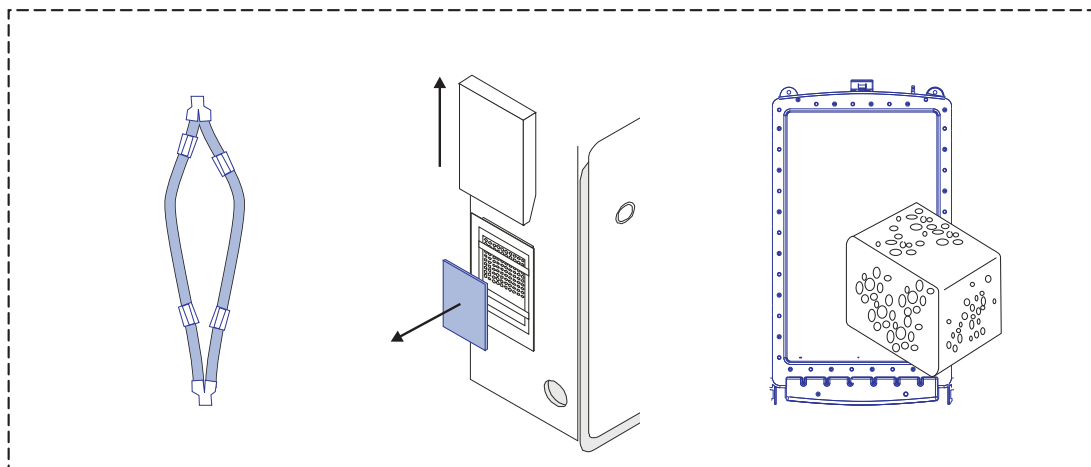
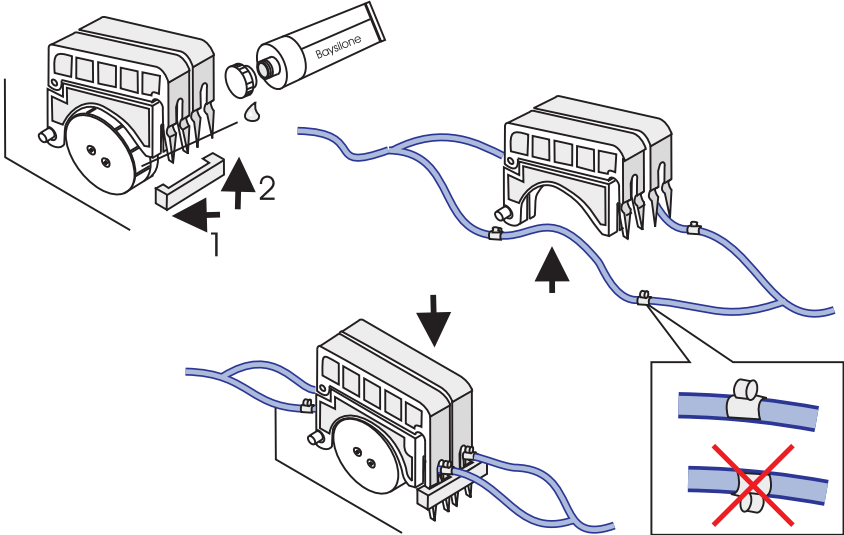

Fig. 6-27 Metering tube replacement



6.1.3 Every 12 or 24 months

As part of the service contract by customer service:

after 12 months

- Replacement of the metering tubes together with the connecting tubes
- Replacement of the pump cartridges and pump rollers
- Replacement of compressor air filter

after 24 months

- Replacement of compressor

Fig. 6-28

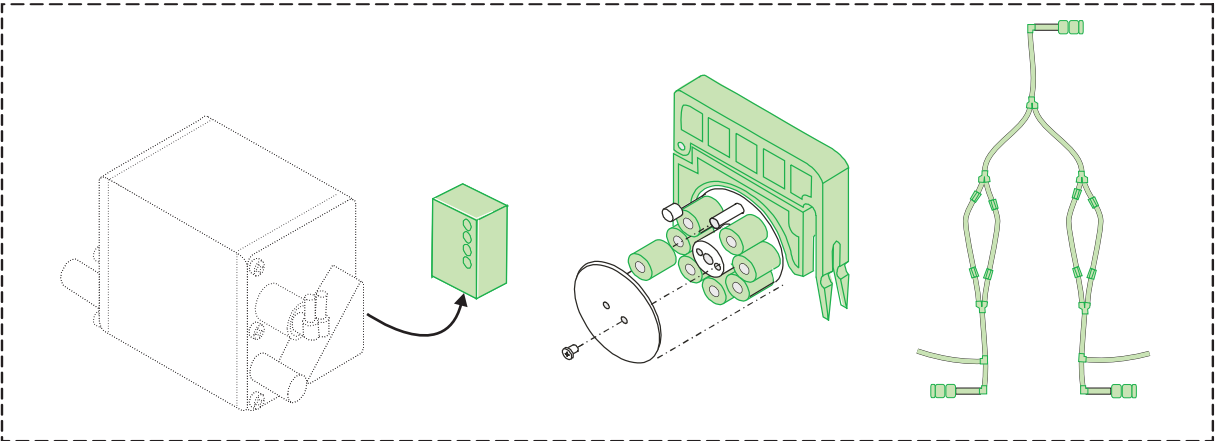

6.1.4 Menu-based cleaning

⚠ DANGER
<p>Potential danger with contact with chemical/biological substances. Working with chemical samples, standards and reagents can be dangerous. Make yourself familiar with the necessary safety procedures and the correct handling of the chemicals before use and read and follow all relevant safety data sheets.</p>

Normal operation of this device may require the use of samples that are biologically unsafe.

⚠ WARNING
<p>Observe all cautionary information printed on the original solution containers and safety data sheets prior to their use. Dispose of all consumed solutions in accordance with the local and national regulations and laws. Select the type of protective equipment suitable to the concentration and quantity of the dangerous material being used. Observe instructions and safety information (information on risks and safety) on the containers for the chemicals used. Wear safety clothing: Lab coat, Safety glasses, Rubber gloves</p>

Action	FILTRAX display
1. On all process instruments connected and on the FILTRAX open the [+SERVICE] menu, then the [+FILTERCLEANING] menu.	+FILTERCLEANING NO SAMPLE!
2. Lift the module carrier out of the tank or flume and acknowledge with [ok].	REM.MOD.CARRIER
3. Pull off the air and sample tubes connected to the module carrier, carefully pull out the filter modules and acknowledge with [ok].	REMOVE MODUL
NOTICE	
As far as possible do not touch the delicate membranes and never allow the membranes to dry out, if necessary store the filter modules in the plastic bags supplied!	
4. Carefully clean the filter modules using 5% chlorine bleach (sodium hypochlorite) or 5% hydrochloric acid (for high iron concentrations) and a soft sponge, during this process do not soil the air and sample suction pipe!	CLEAN MODUL
⚠ WARNING	
Observe the safety precautions when handling the cleaning solution and wear appropriate safety clothing! The chlorine bleach must not come into contact with reagents containing acids, chlorine gas will be formed!	
5. After leaving to soak for 10 minutes, slide the filter modules directly back into the module carrier, without prior rinsing with water, so that the sample tubes are cleaned with the solution left in the filter - acknowledge cleaning with [ok].	CLEAN MODUL
6. Immerse module carrier again and acknowledge with [ok].	REPLACE MODUL
7. Activate cleaning of the sample pipes with the [PREPUMP] function (600 seconds - counter counts backwards, the date for the operating time counter [CLEANED] is now updated automatically). After completion of the prepumping program, place all instruments connected back in operation.	PREPUMP 600 s

6.1.5 Cleaning with cleaning container (option)

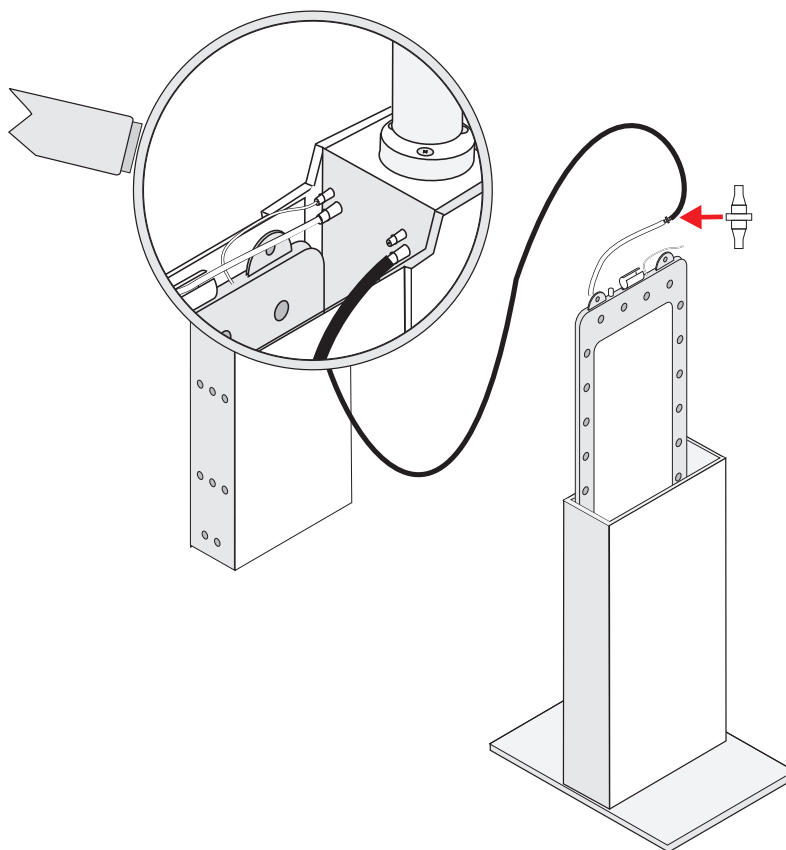

Action	FILTRAX display
1. On all process instruments connected and on the FILTRAX open the [+SERVICE] menu to prevent the process instruments drawing in cleaning solution. Choose the [+FILTERCLEANING] menu.	[+FILTERCLEANING], NO SAMPLE
2. Lift the module carrier out of the tank or flume and accept with [ok].	REM.MOD.CARRIER
3. Pull off the air and sample tubes connected to the module carrier, carefully pull out the filter modules and acknowledge with [ok].	REMOVE MODUL
NOTICE	
As far as possible do not touch the delicate membranes and never allow the membranes to dry out.	CLEAN MODUL
4. Slide the filter modules into the cleaning container. Lay tubes as per diagram.	
5. Carefully fill the cleaning container with 5% chlorine bleach (sodium hypochloride)!	
⚠ WARNING	REPLACE MODUL
Observe the safety precautions when handling the cleaning solution and wear appropriate safety clothing! The chlorine bleach must not come into contact with reagents containing acids, chlorine gas will be formed!	
6. Soaking time: 10 minutes, then acknowledge with [ok]. Further clean or clean mechanically in case of heavy soiling.	PREPUMP 600 s (count down to 0)
7. Activate the cleaning of the sample pipes using the [PREPUMP] function (counter counts backwards from 600 s, the date for the operating time counter [CLEANED] is now updated automatically).	
8. Slide the filter modules back into the module carrier and immerse the module carrier again at the location for the measurements.	

Maintenance

9. Open the [+SERVICE] menu and then the [PREPUMP] function.	[+SERVICE] PREPUMP 600 s (count down to 0)
10. 10-15 minutes later place all instruments back in operation.	

6.1.6 Cleaning with cleaning set (option)

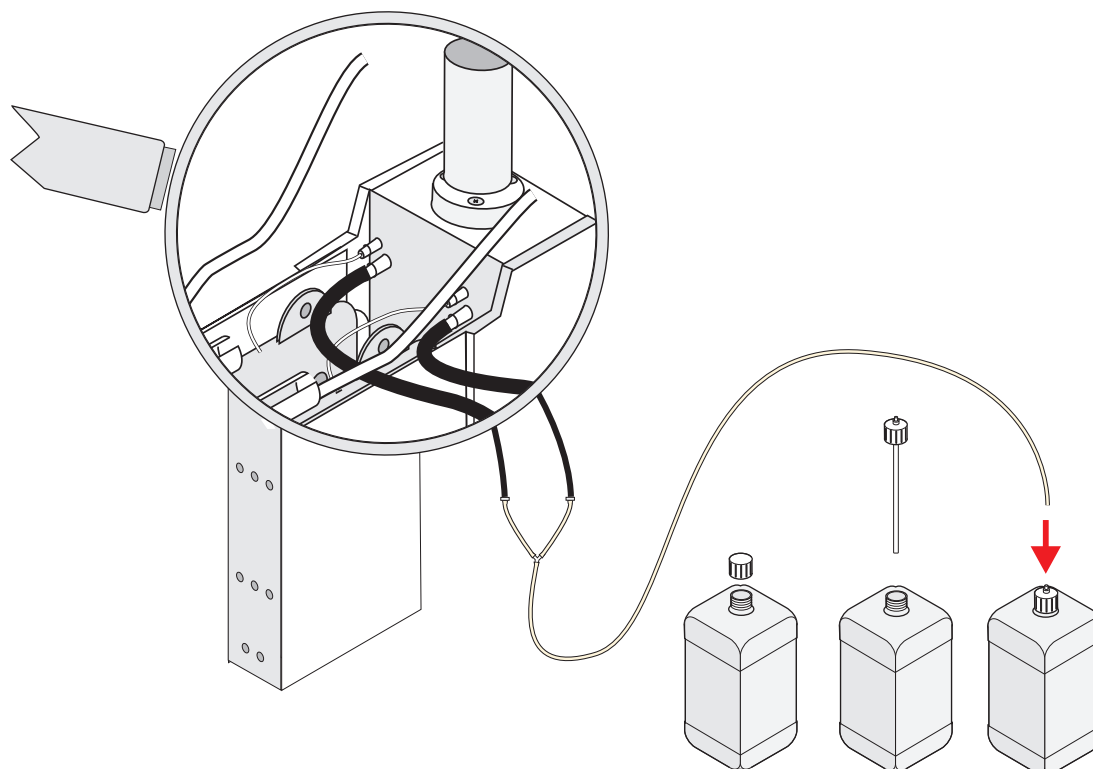

Action	Menu/acknowledge
1. On all process instruments connected and on the FILTRAX open the [+SERVICE] menu to prevent the process instruments drawing in cleaning solution. Choose the [+FILTERCLEANING] menu.	[+FILTERCLEANING], NO SAMPLE
2. Lift the module carrier out of the tank or flume and accept 2 x with [ok].	REM.MOD.CARRIER REMOVE MODUL
3. Carefully fill the cleaning bottle with 5% chlorine bleach (sodium hypochloride)!	CLEAN MODUL
⚠ WARNING	
Observe the safety precautions when handling the cleaning solution and wear appropriate safety clothing! The chlorine bleach must not come into contact with reagents containing acids, chlorine gas will be formed!	
4. Pull off the sample tubes connected to the module carrier and acknowledge with [ok]. Lay tubes as per diagram.	
5. Activate the cleaning of the sample pipes using the [PREPUMP] function (counter counts down from 600 s, the date for the operating time counter [CLEANED] is now updated automatically).	PREPUMP 600 s (count down to 0)
6. Lay the tubes for the filter modules as before and immerse the module carrier again at the location for the measurements.	
7. Open the [+SERVICE] menu and then the [PREPUMP] function.	[+SERVICE] PREPUMP 600 s (count down to 0)
8. 10-15 minutes later place all instruments back in operation.	

Note: FILTRAX has three different types of error messages

7.1 Messages

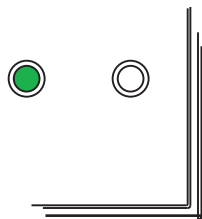

Only text is displayed referring to the need for the replacement of consumables - the green signal lamp remains active.

FAULT	CAUSE	RECTIFICATION
AIRFILTER COMP.	The operating time counter for the compressor air filter [AIR F.C.] has expired	Replace compressor air filter and reset operating time counter
AIRFILTER CASE	The operating time counter for the control unit air filter [AIR F.H.] has expired	Replace control unit air filter and reset operating time counter
PUMPWHEELS	The operating time counter for the pump rollers [P.ROLL] has expired	Replace pump rollers and reset operating time counter
PUMPCASSETTE	The operating time counter for the pump cartridges [P.CARTR.] has expired	Replace pump cartridges and reset operating time counter
COMPRESSOR	The operating time counter for the compressor [COMP.] has expired	Replace compressor and reset operating time counter

7.2 Warnings

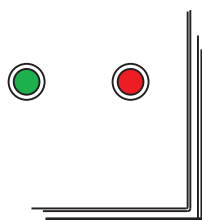

Text is displayed, both signal lamps are active and the warning relay contact is set. If possible rectify without delay!

FAULT	CAUSE	RECTIFICATION
PUMPTUBES	The operating time counter for the pump tubes [P.TUBES] has expired	Replace pump tubes and reset operating time counter
LESS SAMPLE	The amount of sample from a module is below the threshold set under [WARNING <]	Check all tubes, if necessary clean filter modules
TEMPERATURE	The temperature in the control unit is too high, the filter module venting is shut down automatically	Check fans in the control unit, if necessary replace filter mats, reduce ambient temperature
TEST SETTINGS	On the [+DEVICEDATA] menu some settings may have been lost	Check all instrument settings on the [+DEVICEDATA] menu and [+SERVICE] menu

7.3 Faults

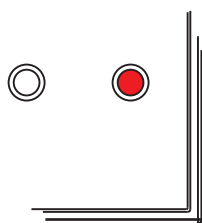

Text is displayed, the red signal lamp is active and the fault relay contact is set. Action must be taken immediately!

FAULT	CAUSE	RECTIFICATION
FAULT PHOTOMETER	Electronic fault or no measurable sample flow rate (e.g. valve faulty, air bubbles due to lack of sample)	Check sample flow rate, if necessary clean sample pipe, call customer service
WARM UP MODE!	The temperature in the housing is <1 °C, the instrument is warming up	Wait until the heater has raised the temperature in the housing to > 1° C, the warm up phase then takes a further 30 min. Keep door closed!
FAULT SAMPLE	The amount of sample from a module is below the threshold set under [FAULT <]	Check all tubes and pumps, if necessary clean filter modules and sample pipe
FAULT DEVICE	Serious electronic fault / bus fault Normal operation is no longer possible!!	Unplug from the mains for 1 min, if the fault is still present Call customer service
TEMP.SENSOR	Temperature sensor faulty or not fitted Normal operation is stopped because it is no longer possible to regulate the temperature!	Check connection to temperature sensor, Call customer service

7.4 Voltage drop (power failure)

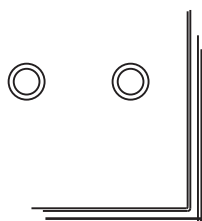

On a power failure both relay contacts are closed (warning and fault signalling).

Baysilone paste	EZH051
Sample tube 2 m (6.6 ft) unheated	LZX675
Sample tube 10 m (32.8 ft) heated 230 V	LZX672
Sample tube 10 m (32.8 ft) heated 115 V	LZX671
Sample tube 20 m (65.5 ft) heated 230 V	LZX674
Sample tube 20 m (65.5 ft) heated 115 V	LZX673
Sample tube 30 m (98.4 ft) heated 230 V*	LZX675
Filter mat set (8 pieces) for control unit	LZX017
Filter module completely packaged	LZX677
Plastic bag for storing filter module	EYV017
Set of tubes for one year	LZX667
Set of annual consumables	LZX018
Compressor 115 V	LZX025
Compressor 230 V	LZX024
Module carrier complete with 5 m suction tube 230 V	LZX670
Module carrier complete with 5 m suction tube 115 V	LZX669
Sample connecting tube (external), 6m, 2/4 mm black	HLS191
Pump cartridge	LZP777
Pump rollers 2-channel (5 pieces)	LZX019
Valve (2/2 way)	LZV205

Accessories

Tank edge fastening, module carrier	LZY714.99.43020
Tank edge fastening, module carrier (mounting pipe with slot on side)	LZY714.99.43050
Bracket for control unit	LZX676
Tube adapter set for instruments connected in series	LZX701
Pipe clamps	EHK063
Second fastening point for mounting pipe (for long struts)	LZY714.99.03000
Cleaning container	LZX216
Cleaning set	LZX217

*. 30 m (98.4 ft) version is not available at 115V AC.

HACH COMPANY World Headquarters

P.O. Box 389, Loveland, CO 80539-0389 U.S.A.
Tel. (970) 669-3050
(800) 227-4224 (U.S.A. only)
Fax (970) 669-2932
orders@hach.com
www.hach.com

HACH LANGE GMBH

Willstätterstraße 11
D-40549 Düsseldorf, Germany
Tel. +49 (0) 2 11 52 88-320
Fax +49 (0) 2 11 52 88-210
info-de@hach.com
www.de.hach.com

HACH LANGE Sàrl

6, route de Compois
1222 Vérenaz
SWITZERLAND
Tel. +41 22 594 6400
Fax +41 22 594 6499

